

目录/CATALOGUE

1	256898501001 驱动系统/DRIVE SYSTEM	1
2	256898501002 驱动桥/DRIVE AXLE(30-35Q)	2
3	256898501003 制动器/LEFT BRAKE(30-35Q)	3-4
4	256898501004 驱动桥/DRIVE AXLE(25-28Q)	5
5	256898501005 制动器(左)/LEFT BRAKE(25-28Q)	6
6	256898501006 变速箱(ZN)/GEARBOX(ZN)	7
7	256898501007 差速器(ZN)/DIFFERENTIAL MECHANISM(ZN)	8
8	256898501008 变速箱(ZC)/GEARBOX(ZC)	9
9	256898501009 差速器(ZC)/DIFFERENTIAL MECHANISM(ZC)	10
10	256898501010 前轮总成/WHEEL ASSEMBLY(30-35Q)	11
11	256898501011 前轮总成/WHEEL ASSEMBLY(25-28Q)	12
12	256898501012 后轮总成/WHEEL ASSEMBLY(30-35Q)	13
13	256898501013 后轮总成/WHEEL ASSEMBLY(25-28Q)	14
14	256898501014 起升电机安装/MOTOR INSTALLATION	15
15	256898501015 行车制动安装/DRIVING BRAKING INSTALLATION	16
16	256898501016 驻车制动安装/PARKING BRAKING INSTALLATION	17
17	256898501017 转向装置及安装/STEERING GEAR AND INSTALLATION	18
18	256898501018 转向桥及安装/STEERING BRIDGE AND INSTALLATION	19-20
19	256898501019 转向油缸/STEERING CYLINDER	21
20	256898501020 座椅盖板安装/SEAT COVER MOUNTING	22
21	256898501021 右盖板安装/SIDE PANEL INSTALLATION	23
22	256898501022 左侧板安装SIDE PANEL INSTALLATION	24
23	256898501023 仪表罩安装/INSTRUMENT COVER INSTALLATION	25
24	256898501024 平衡重及安装/BALANCE WEIGHT AND MOUNTING	26
25	256898501025 脚踏板安装/FOOT PEDAL	27
26	256898501026 液压系统/HYDRAULIC	28
27	256898501027 多路换向阀操纵(二联)/MULTI-WAY REVERSING VALVE CONTROL(TWO)	29
28	256898501028 多路换向阀操纵(三联)MULTI-WAY REVERSING VALVE CONTROL(THREE)	30
29	256898501029 多路换向阀操纵(四联)MULTI-WAY REVERSING VALVE CONTROL(FOUR)	31
30	256898501030 工作油箱装置及安装/WORK TANK INSTALLATION AND INSTALLATION	32
31	256898501031 车架装配/FRAME ASSEMBLY	33
32	256898501032 护顶架装配/TOP GUARD ASSEMBLY	34
33	256898501033 货叉/FORK	35
34	256898501034 倾斜油缸/TILT CYLINDER(30-35Q)	36
35	256898501035 倾斜油缸/TILT CYLINDER(25-28Q)	37
36	256898501036 门架(标准门架25-28Q)/MAST(stand mast25-28Q)	38-40
37	256898501037 门架(标准门架30-35Q)/MAST(stand mast30-35Q)	41-43
38	256898501038 货叉架(标准门架)/FORK ARM CARRIER(stand mast)	44
39	256898501039 起升油缸(标准门架)/LIFTING PIPE(stand mast)	45-48
40	256898501040 门架起升管路(标准门架)/SINGLE ADDITIONAL TUBE(stand mast)	49
41	256898501041 单附加管路(标准门架)SINGLE ADDITIONAL TUBE(stand mast)	50
42	256898501042 双附加管路(标准门架)DOUBLE ADDITIONAL TUBE(stand mast)	51-52
43	256898501043 门架(三级全自由门架)/MAST(three stage full free)	53-55
44	256898501044 货叉架(三级全自由门架)/FORK ARM CARRIER(three stage full free)	56
45	256898501045 短起升油缸(三级全自由门架)/SHORT LIFTING CYLINDER(three stage full free)	57-59
46	256898501046 起升油缸(三级全自由门架)/LIFTING CYLINDER(three stage full free)	60-64
47	256898501047 起升管路(三级全自由门架)/LIFTING CYLINDER(three stage full free)	65-66
48	256898501048 侧移器及管路安装(三级全自由)/Side shifter and pipeline installation(three stage full free)	67
49	256898501049 双附加管路(三级全自由)/DOUBLE ADDITIONAL TUBE(three stage full free)	67-68
50	256898501050 门架(两级全自由门架)/MAST(two stage full free)	69-71
51	256898501051 货叉架(两级全自由门架)/FORK ARM CARRIER(two stage full free)	72
52	256898501052 短起升油缸(两级全自由门架)/SHORT LIFTING CYLINDER(two stage full free)	73-75
53	256898501053 起升油缸(两级全自由门架)/LIFTING CYLINDER(two stage full free)	76-77
54	256898501054 起升管路(两级全自由门架)/LIFTING CYLINDER(two stage full free)	78
55	256898501055 单附加管路(两级全自由门架)/pipeline installation(two stage full free)	79-80
56	256898501056 双附加管路(两级全自由门架)/pipeline installation(two stage full free)	81-82
57	256898501057 电器系统/ELECTRONIC	83-84
58	256898501058 电控组件/ELECTRONIC COMPONENTS—ACM系统	85
59	256898501059 电控组件/ELECTRONIC COMPONENTS—Inmotion系统	86
60	256898501060 电控组件/ELECTRONIC COMPONENTS—Curtis-F系统	87
61	256898501061 电控组件/ELECTRONIC COMPONENTS—Curtis系统	88
62	256898501062 蓄电池/BATTERY	89-90
63	256898501063 蓄电池/BATTERY	91
64	256898501064 蓄电池/BATTERY	92

256898501003 制动器/LEFT BRAKE (30-35Q)

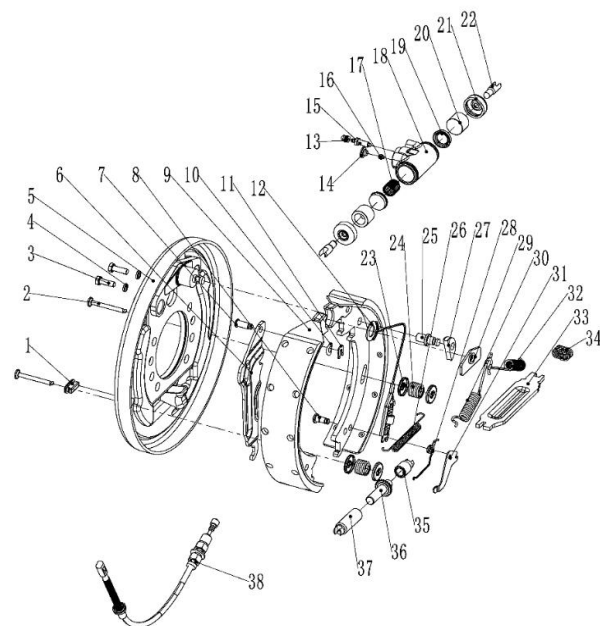

序号/NO	编码/SN	名称	Name	数量/QTY	备注/Remark
1	256898523530	胶堵24433-70040G	Rubber plug 24433-70040G		
2	256898523531	压簧拉杆24433-70010G	Spring tension rod 24433-70010G		
3	256898523532	螺栓M8×1.25×20GB/T5783-2000	Bolt M8 × one point two five × 20GB/T		
4	910400500005	弹簧垫圈GB93-6	Spring washer GB93-6		
5	256898523533	制动器底板总成(左) 24433-72000G	Brake base plate assembly (left) 2443		左右对称
5	256898523534	制动器底板总成(右)	Brake backing plate assembly (right)		
6	256898523535	手制动拉杆(左) 24433-70140G	Hand brake rod (left) 24433-70140G		左右对称
6	256898523536	手制动拉杆(右)	Hand brake rod (right)		
7	256898523537	销钉2 24433-70150G	Pin 2 24433-70150G		
8	256898523538	销钉1 24433-70110G	Pin 1 24433-70110G		
9	256898523539	制动蹄带摩擦片总(左) 24433-71000G	Brake shoe with friction plate assembl		左右对称
9	256898523540	制动蹄带摩擦片总(右)	Brake shoe with friction plate assembl		
10	256898523541	弹性垫片24433-70160G	Elastic gasket 24433-70160G		
11	256898523542	杆销挡圈24433-70170G	Rod pin retainer 24433-70170G		
12	256898523543	弹簧拉线装置24433-73000G	Spring cable device 24433-73000G		
A	256898523544	制动分泵总成	Brake wheel cylinder assembly		包含13-22
13	▲	分泵放气螺钉帽24433-76100G	Cylinder bleed screw cap 24433-7610		
14	▲	螺纹防护塞24433-76080G	Thread protection plug 24433-76080G		
15	▲	分泵放气螺钉24433-76090G	Cylinder bleed screw 24433-76090G		
16	▲	制动分泵油塞24433-76070G	Brake wheel cylinder oil plug 24433-76		
17	▲	分泵弹簧24433-76040G	Cylinder spring 24433-76040G		
18	▲	制动分泵缸24433-76010G	Brake wheel cylinder 24433-76010G		
19	▲	分泵皮碗24433-76030G	Cylinder cup 24433-76030G		
20	▲	分泵活塞24433-76020G	Cylinder piston 24433-76020G		
21	▲	分泵护罩24433-76050G	Cylinder shield 24433-76050G		
22	▲	分泵活塞顶杆24433-76060G	Cylinder piston rod 24433-76060G		
23	256898523545	压簧座24433-70020G	Pressure spring seat 24433-70020G		
24	256898523546	压簧24433-70030G	Compression spring 24433-70030G		
25	256898523547	销钉4 24433-70801	Pin 4 24433-70801		
26	256898523548	拉簧24433-70050G	Tension spring 24433-70050G		
27	256898523549	导向块24433-70080G	Guide block 24433-70080G		

256898501005 制动器 (左) /LEFT BRAKE (25-28Q)

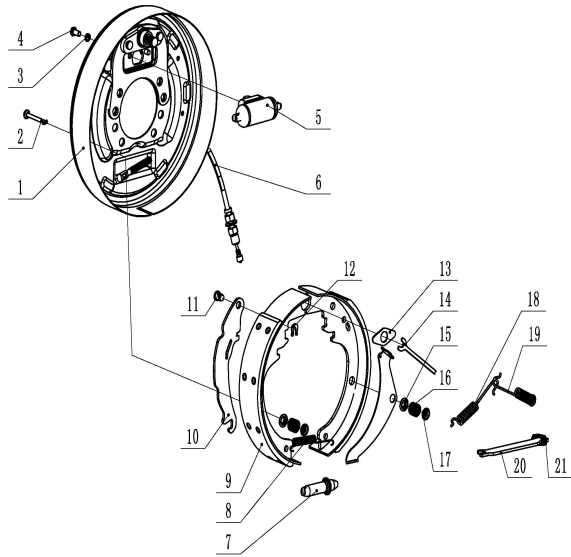

序号/NO	编码/SN	名称	Name	数量/QTY	备注/Remark
1	256798523530	制动器底板总成23653-73011	Brake base plate assembly 23653-73011	1	左右对称
1	256798523531	制动器底板总成 (右)	Brake backing plate assembly (right)	1	
2	256798523532	压簧拉杆23653-72101	Spring tension rod 23653-72101	4	
3	910400500018	弹簧垫圈GB93-6	Spring washer GB93-6	2	
4	910100300020	螺栓GB5782-M8x16	Bolt GB5782-M8x16	2	
5	256798523533	制动分泵总成22373-72041	Brake wheel cylinder assembly 22373-72041	1	
6	256798523534	制动器钢索总成OC11246-14603	Brake cable assembly OC11246-14603	1	左右对称
6	256798523535	制动器钢索总成右OC11246-24603	Brake cable assembly right OC11246-24603	1	
7	256798523536	间隙调整器23653-72041	Clearance adjuster 23653-72041	1	
8	256798523537	弹簧23653-72051	Spring 23653-72051	1	
9	256798523538	摩擦片总成23653-73021	Friction plate assembly 23653-73021	2	左右对称
9	256798523539	摩擦片总成 (右)	Friction plate assembly (right)	1	
10	256798523540	手制动拉杆23653-72071C	Hand brake rod 23653-72071C	1	左右对称
10	256798523541	手制动拉杆 (右)	Hand brake rod (right)	1	
11	256798523542	支撑销22673-72231	Support pin 22673-72231	1	
12	256798523543	弹性垫片24433-70160G	Elastic gasket 24433-70160G	1	
13	256798523544	垫片23653-72131	Gasket 23653-72131	1	
14	256798523545	顶杆23653-72161	Push rod 23653-72161	1	
15	256798523546	压簧座23653-72121	Pressure spring seat 23653-72121	4	
16	256798523547	弹簧23653-72091	Spring 23653-72091	4	
17	256798523548	压簧盖23653-72111	Spring compression cover 23653-72111	4	
18	256798523549	回位弹簧23673-72261	Return spring 23673-72261	1	
19	256798523550	拉簧2353-72171	Tension spring 2353-72171	1	
20	256798523551	手制动推杆23653-72081	Hand brake push rod 23653-72081	1	左右对称
20	256798523552	手制动推杆 (右)	Hand brake push rod (right)	1	
21	256798523553	压缩弹簧23673-72391	Compression spring 23673-72391	1	

256898501006 变速箱 (ZN) /GEARBOX (ZN)

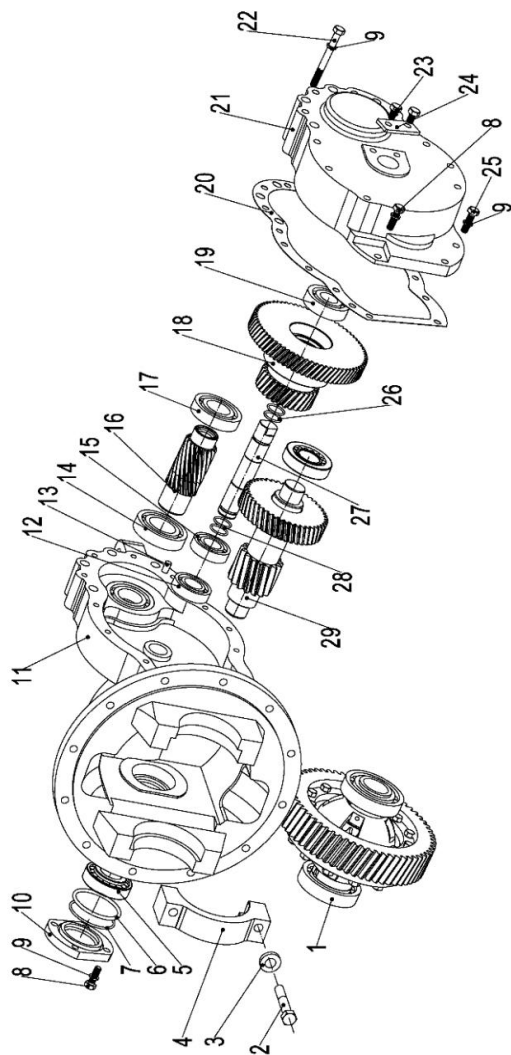

序号/NO	编码/SN	名称	Name	数量/QTY	备注/Remark
1	256898514001	差速器总成HDCS35IIIA. 901	Differential assembly HDCS35IIIA.901	1	
2	256898524001	螺栓YDS30. 089	Bolt YDS30.089	4	
3	256898524002	重型弹簧垫圈GB/T7244-14	Heavy-duty spring washer	4	
4	256898524003	轴承座YDS30. 072	bearing pedestal YDS30.072	2	
5	255098524023	圆锥滚子轴承32207	Bearing 32207	2	
6	256898524004	调整垫YDS30. 090	Adjustable pad YDS30.090	3/4	
7	256898524005	O形圈73×3.1 GB1235	O-ring 73×3.1 GB1235	1	
8	910100300036	六角头螺栓GB5783-M10×25	Bolt GB5783-M10×25	5	
9	910400500007	标准型弹簧垫圈GB93-10	Spring Washer GB93-10	19	
10	256898524006	轴承盖YDS30. 168	Bearing cap YDS30.168	1	
11	256898524007	箱体HDCS35IIIA. 001	Box HDCS35IIIA.001	1	
12	910700200021	深沟球轴承GB/T276-6206	Bearing GB/T276-6206	1	
13	255098526008	圆柱销GB/T119.1-10×20	Pin GB/T119.1-10×20	2	
14	910700200023	深沟球轴承GB/T276-6208	Bearing GB/T276-6208	1	
15	256898524008	圆柱滚子轴承GB/T283-NJ2206E	Bearing GB/T283-NJ2206E	1	
16	256898524009	输入轴HDCS35IIIA. 003	Input axis HDCS35IIIA.003	1	
17	910700200024	深沟球轴承GB/T276-6209	Bearing GB/T276-6209	1	
18	256898524010	双联齿轮组件HDCS35IIIA. 803	Double gear assembly HDCS35IIIA.803	1	
19	910700200033	深沟球轴承6307 GB/T 276	Bearing 6307 GB/T 276	1	
20	256898524011	箱体箱盖结合面纸垫HDCS35IIIA. 010	Paper pad HDCS35IIIA.010	1	
21	256898524012	箱盖HDCS35IIIA. 002	Case cover HDCS35IIIA.002	1	
22	910100100040	六角头螺栓GB5782-M10×90	Bolt GB5782-M10×90	10	
23	910100300034	六角头螺栓GB5783-M10×16	Bolt GB5783-M10×16	2	
24	256898524013	挡块HDCS25. 008	Link stopper HDCS25.008	1	
25	910100300038	六角头螺栓GB5783-M10×35	Bolt GB5783-M10×35	2	
26	910800100006	O形圈35×3.1 GB1235	O-ring 35×3.1 GB1235	2	
27	256898524014	中间轴HDCS35IIIA. 009	Intermediate shaft HDCS35IIIA.009	1	
28	255098524010	O形圈25×2.65 GB/T3452.1	O-ring 25×2.65 GB/T3452.1	2	
29	256898524015	齿轴组件HDCS35IIIA. 804	Gear shaft components HDCS35IIIA.804	1	

256898501008 变速箱 (ZC) /GEARBOX (ZC)

序号/NO	编码/SN	名称	Name	数量/QTY	备注/Remark
1	910100300036	螺栓M10×25	Bolt M10×25	4	
2	910400500007	弹簧垫圈10	Spring washer 10	20	
3	255098524050	轴承盖Y30H-09001	Bearing cap Y30H-09001	1	
4	910800100032	O型圈75×3.1	O-ring 75×3.1	1	
5	255098524051	齿轴垫片Y30H-09002A	Gear shaft gasket Y30H-09002A	AR	
5	255098524052	齿轴垫片Y30H-09002B	Gear shaft gasket Y30H-09002B	AR	
5	255098524053	齿轴垫片Y30H-09002C	Gear shaft gasket Y30H-09002C	AR	
5	255098524054	齿轴垫片Y30H-09002D	Gear shaft gasket Y30H-09002D	AR	
6	255098524055	箱体组件HDCSB30-01200	Body components HDCSB30-01200	1	
7	255098524056	轴承座锁片YQX25-01008	Lock plate of bearing seat YQX25-01008	4	
8	255098524023	圆锥滚子轴承32207	Bearing 32207	2	
9	910700200021	深沟球轴承6206	Bearing 6206	2	
10	255098524057	齿轴HDCSB30-04000-1	Axis HDCSB30-04000-1	1	
11	255098524058	双联齿轮HDCSB30-03000-1	Duplicate gear HDCSB30-03000-1	1	
12	910100300039	螺栓 M10X40	Bolt M10X40	2	
13	910100100125	螺栓 M10X100	Bolt M10X100	12	
14	910100300034	螺栓 M10X16	Bolt M10X16	2	
15	255098524059	挡块HDCS25-03001	Link stopper HDCS25-03001	1	
16	255098524060	箱盖HDCSB30-01002	Case cover HDCSB30-01002	1	
17	255098524042	深沟球轴承6306	Bearing 6306	1	
18	255098524010	O型圈 25X2.65	O-ring 25X2.65	2	
19	255098524061	轴HDCSB30-03003	Axis HDCSB30-03003	1	
20	910700200023	深沟球轴承 6208	Bearing 6208	1	
21	255098524062	密封盖HDCSB30-02002	Seal cover HDCSB30-02002	2	
22	255098524063	输入轴HDCSB30-02001-1	Input axis HDCSB30-02001-1	1	
23	910700200024	深沟球轴承 6209	Bearing 6209	1	
24	910600100029	圆柱销10X24	Pin 10X24	2	

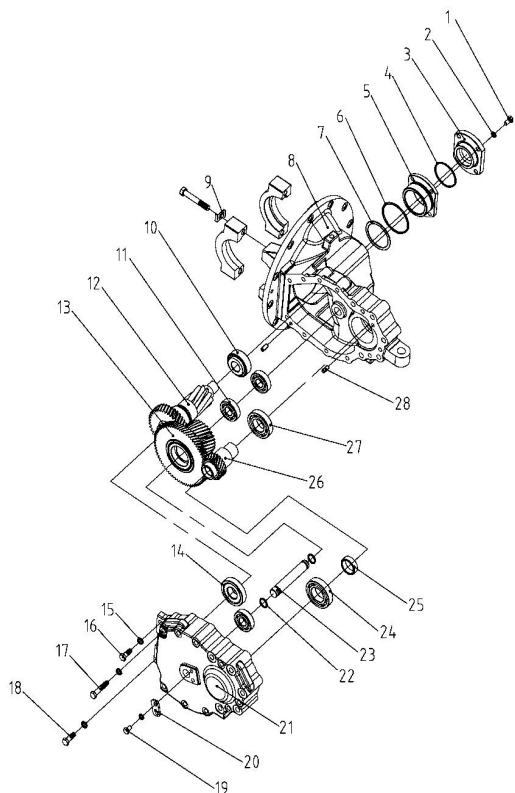

256898501009 差速器 (ZC) / DIFFERENTIAL MECHANISM (ZC)

序号/NO	编码/SN	名称	Name	数量/QTY	备注/Remark
1	256898525018	深沟球轴承 6213GB/T 276	Bearing 6213GB/T 276	2	
2	256898525019	法兰面螺栓 M14*1.5*60GB/T 16674.2	Bolt M14*1.5*60GB/T 16674.2	12	
3	256898525020	齿圈HDCS30-05001	Gear ringHDCS30-05001	1	
4	256898525021	右差速器壳HDCS30-05003	Right differential housing HDCS30-05003	1	
5	256898525022	半轴垫圈Y30H-10006	Half shaft washerY30H-10006	2	
6	256898525023	半轴齿轮Y30H-10007	Axle shaft gearY30H-10007	2	
7	256898525024	十字轴Y30H-10003	Universal joint pin Y30H-10003	1	
8	256898525025	行星齿轮Y30H-10005	Planetary gear Y30H-10005	4	
9	256898525026	行星垫圈Y30H-10004	Planetary washer Y30H-10004	4	
10	256898525027	左差速器壳HDCS30-05002	Left differential housingHDCS30-05002	1	

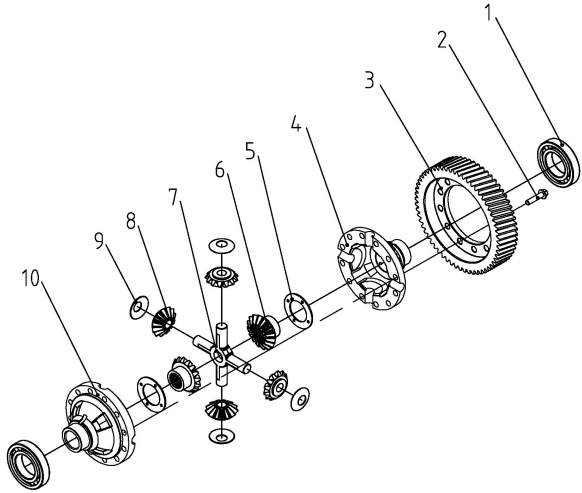

256898501010 前轮总成/WHEEL ASSEMBLY (30-35Q)

序号/NO	编码/SN	名称	Name	数量/QTY	备注/Remark
A	256813010001	轮胎总成28X9-15-14PR(充气)	Tire assembly 28X9-15-14PR(pneuma	2	
	256813010002	轮胎总成28X9-15(实心)	Tire assembly 28X9-15(soild)	2	选装/Optional
	256813010003	轮胎总成28X9-15(环保)	Tire assembly 28X9-15(environmental	2	选装/Optional
1	256813011002	轮胎28X9-15-14PR(充气)	Tire 28X9-15-14PR(pneumatic)	2	
	256813012002	轮胎28X9-15(实心)	Tire 28X9-15(soild)	2	选装/Optional
	256813012003	轮胎28X9-15(环保)	Tire 28X9-15(environmentally)	2	选装/Optional
2	910300200003	轮辋总成(7.00T-15)	Rim assembly(7.00T-15)	2	

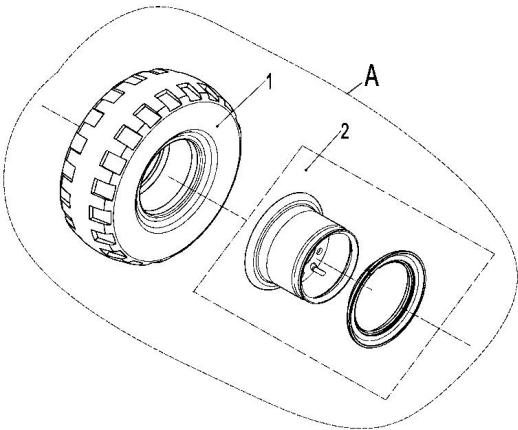

256898501011 前轮总成/WHEEL ASSEMBLY (25-28Q)

序号/NO	编码/SN	名称	Name	数量/QTY	备注/Remark
A	256713010001	轮胎总成7.00-12-12PR(充气)	Tire assembly 7.00-12-12PR(pneuma	2	25-28Q/选装
A	256713010002	轮胎总成7.00-10(实心)	Tire assembly 7.00-10(soild)	2	25-28Q/选装
A	256713010003	轮胎总成7.00-10(环保)	Tire assembly 7.00-10(environmenta	2	25-28Q/选装
1	910300200003	螺母GB6171-M12x1.25-10	Nut GB6171-M12x1.25-10	16	
2	910400500008	弹簧垫圈GB93-12	Spring washerGB93-12	16	
3	256713021001	轮辋总成5.00S-12	Outer assembly 5.00S-12	2	
4	256713012001	轮胎7.00-10-12PR(充气)	Tire 7.00-10-12PR(pneumatic)	2	25-28Q/选装
4	256713012002	轮胎7.00-10(实心)	Tire 7.00-10(solid)	2	25-28Q/选装
4	256713012003	轮胎7.00-10(环保)	Tire 7.00-10(environmentally)	2	25-28Q/选装
5	256713021002	轮辋总成5.00S-12	Rimassembly 5.00S-12	2	
6	255013020001	轮辋螺栓M12x1.25x26	Rim bolt M12x1.25x26	16	

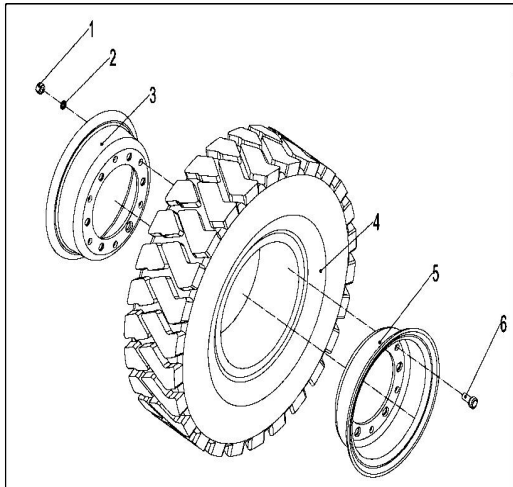

256898501015 行车制动安装/DRIVING BRAKING INSTALLATION

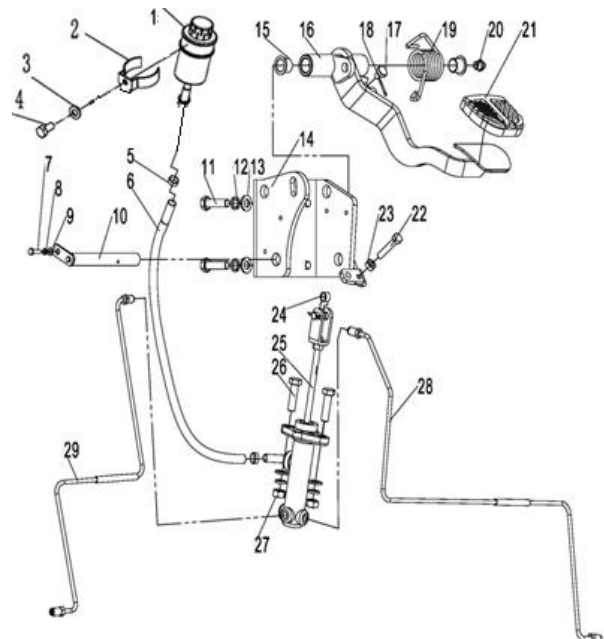

序号/NO	编码/SN	名称	Name	数量/QTY	备注/Remark
1	275011520020	油杯	Grease nipple	1	
2	256811511020	油杯固定环	Bracket	1	
3	910400500007	弹簧垫圈GB93-8	Washer GB93-8	1	
4	910100300020	螺栓GB5783-M8x16-8.8	Bolt GB5783-M8x16-8.8	1	
5	911000600001	喉箍QC/T390-(11-14)	Hose clamp QC/T390-(11-14)	2	
6	255011520021	连接管	Connecting pipe	1	
7	910100300003	螺栓GB5783-M5x12-8.8	Bolt GB5783-M5x12-8.8	1	
8	910400500004	弹簧垫圈GB93-5	Washer GB93-5	1	
9	910400100004	平垫圈GB97.1-5-200HV	Washer GB97.1-5-200HV	1	
10	255011510003	带耳轴Φ16x135	Axle Φ16x135	1	
11	910100300039	螺栓GB5783-M10x40-8.8	Bolt GB5783-M10x40-8.8	4	
12	910400500007	弹簧垫圈GB93-10	Washer GB93-10	6	
13	910400100007	平垫圈GB97.1-10-200HV	Washer GB97.1-10-200HV	6	
14	256811511004	脚制动支架焊合	Foot brake holder welding	1	
15	940500100006	复合套Φ16xΦ18x15-SF-1	Bushing Φ16xΦ18x15-SF-1	2	
16	256811511002	踏板焊合	Pedal weiding	1	
17	255011520010	缓冲垫	Damping pad	1	
18	910600600015	开口销GB91-2x20	Split pin GB91-2x20	1	
19	255011520008	扭簧	Spring	1	
20	911200100004	油杯JB7940.1-M10x1	Grease nipple JB7940.1-M10x1	1	
21	255011520013	踏板(橡胶)	Pedal (rubber)	1	
22	910100100023	螺栓GB5782-M8x45-8.8	Bolt GB5782-M8x45-8.8	1	
23	910300100006	螺母GB6170-M8-10	Nut GB6170-M8-10	1	
24	940500100048	复合套Φ10xΦ12x8-SF-1	Bushing Φ10xΦ12x8-SF-1	1	
25	256811510001	制动泵总成	Brake pump assembly	1	
26	910100300038	螺栓GB5783-M10x35-8.8	Bolt GB5783-M10x35-8.8	2	
27	910300100007	螺母GB6170-M10-10	NutGB6170-M10-10	2	
28	256811511009	右制动钢管	Brake steel pipe welding	1	
29	256811511010	左制动钢管	Brake steel pipe welding	1	

256898501016 驻车制动安装/PARKING BRAKING INSTALLATION

序号/NO	编码/SN	名称	Name	数量/QTY	备注/Remark
1	910100300035	螺栓GB5783-M10x20-8.8	Bolt GB5783-M10x20-8.8	2	
2	910400500007	弹簧垫圈GB93-10	Spring washer GB93-10	2	
3	910400100007	平垫圈GB97.1-10-200HV	Washer GB97.1-10-200HV	2	
4	256812021003	垫板(手制动)	Backing plate (Parking brake)	1	
5	XG1801542747	手制动总成	Parking Brake Assembly	1	
6	910400100005	平垫圈GB97.1-6-200HV	Washer GB97.1-6-200HV	4	
7	910400500005	弹簧垫圈GB93-6	Spring washer GB93-6	4	
8	910100300010	螺栓GB5783-M6x16-8.8	Bolt GB5783-M6x16-8.8	4	

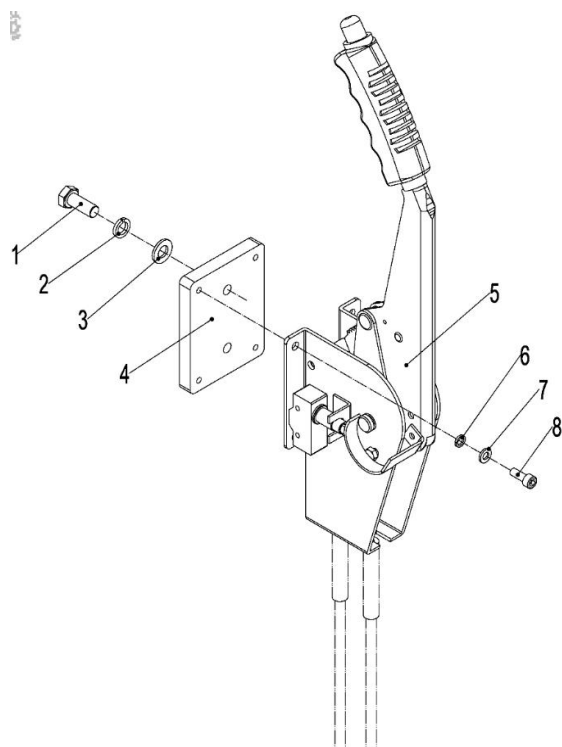

256898501017 转向装置及安装/STEERING GEAR AND INSTALLATION

序号/NO	编码/SN	名称	Name	数量/QTY	备注/Remark
1	255015010007	可调手柄	The adjustable handle	1	
2	910600400011	弹性圆柱销GB879.1-4x30	Elastic cylinder pin GB879.1-4x30	1	
3	255015020025	夹柄螺套	Clamp holder screw sets	1	
4	910400100008	垫圈Φ20xΦ12x8	GasketΦ20XΦ12X8	1	
5	255015020019	锁紧块	Locking block	1	
6	910300300006	螺母GB6172.1-M12-05	Nut GB6172.1-M12-05	1	
7	910100300057	螺栓GB5783-M12x70-8.8	Bolt GB5783 M12x70-8.8	1	
8	255015010001	转向管柱总成	Steering string assembly	1	
9	255015010003	方向盘	The steering wheel	1	
10	910600700014	销轴GB882-6x26x1.6	Pin GB882-6x26x1.6	1	
11	910600600005	开口销GB91-1.6x10	Cotter pin GB91-1.6x10	1	
12	255015020002	固定座	The fixed seat	1	
13	255015010005	调节杆焊合	Adjust rod welding	1	
14	255015020021	调节螺钉	Adjust the screw	1	
15	911200100004	油杯JB7940.1-M10x1	Oil cup JB7940.1-M10x1	1	
16	940500200016	复合套(带肩)Φ16xΦ18x16-SF-1	Composite set (shoulder)Φ16xΦ18x16	2	
17	255011510003	带耳轴Φ16x135	With trunnionΦ16x135	1	
18	910400100005	平垫圈GB97.1-6-200HV	WasherGB97.1-6-200HV	1	
19	910400500005	弹簧垫圈GB93-6	Spring washerGB93-6	1	
20	910100300009	螺栓GB5783-M6x12-8.8	Bolt GB5783 M6x12-8.8	1	
21	910100300036	螺栓GB5783-M10x25-8.8	Bolt GB5783 M10x25-8.8	4	
22	910400500007	弹簧垫圈GB93-10	Spring washer gb93-10	4	
23	910400100007	平垫圈GB97.1-10-200HV	Washer GB97.1-10-200HV	4	
24	255015010004	支架焊合	Bracket welded	1	
25	255015010012	转向器SCU51/100-FS	Steering SCU51/100-FS	1	

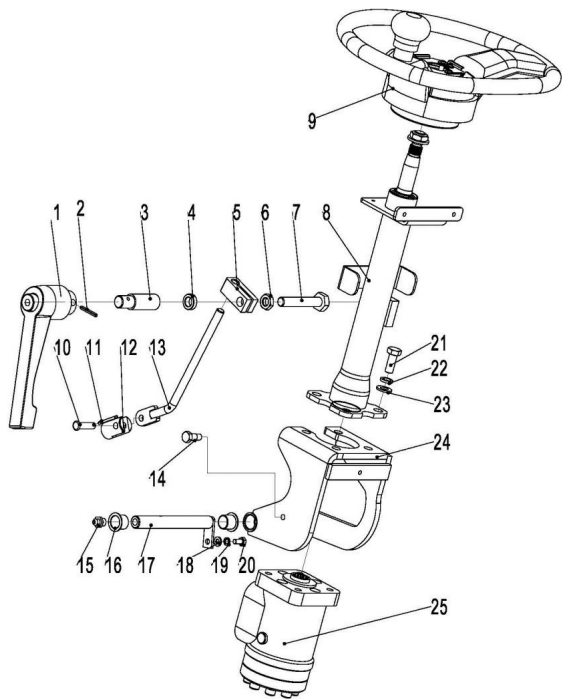

256898501018 转向桥及安装/STEERING BRIDGE AND INSTALLATION

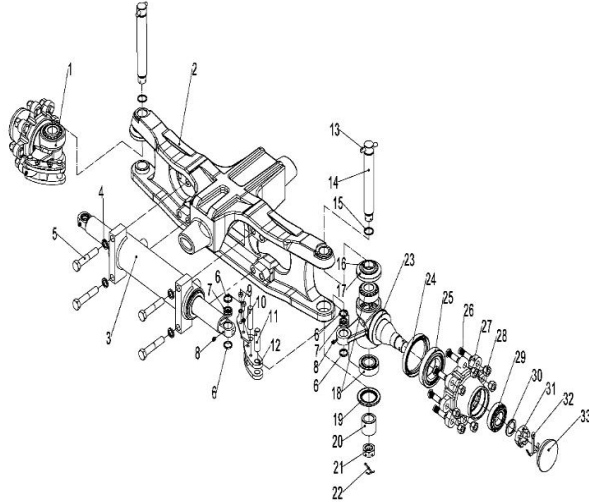

序号/NO	编码/SN	名称	Name	数量/QTY	备注/Remark
A	256816010001	30Q转向桥	30Q steering axle	1	
1	256898526001	左转向节Z30KD011G	Left knuckle Z30KD011G	1	
2	256898526002	桥体ZDS/K30-35D-03	Turn to the bridge ZDS/K30-35D-03	1	
3	256898516001	转向油缸LGZN030K-0100	Steering cylinder LGZN030K-0100	1	
4	910400500010	弹簧垫圈16	Spring washer 16	4	
5	910100100073	六角螺栓M16X65	Bolt M16X65	4	
6	256898526003	衬套Z30KD024	Bush Z30KD024	8	
7	256898526004	关节轴承Z30KD023	Knuckle bearing Z30KD023	4	
8	254198526085	直通式压注油杯M6	Oil cap M6	2	
9	910100300022	六角螺栓M8X18	bolt M8X18	4	
10	910400500006	弹簧垫圈8	Spring washer 8	4	
11	256898526005	连杆销Z30KD025	Link pin Z30KD025	4	
12	256898526006	连杆Z30KD002	Link Z30KD002	2	
13	256898526007	销轴Z30KD004G	Pin Z30KD004G	2	
14	256898526008	转向节主销ZBYD27KD010G	Kingpin ZBYD27KD010G	2	
15	910800100084	O形圈25X2.65	O-ring 25X2.65	2	
16	256898526009	防尘圈座ZBD20KD011G	Shield block ZBD20KD011G	2	
17	256898526010	防尘圈Z30KD006G	Dustband Z30KD006G	2	
18	256898526011	圆锥滚子轴承33206	Bearing 33206	4	
19	256898526012	复合防尘圈Z30KD009G	Composite dust ring Z30KD009G	2	
20	256898526013	衬套ZDS/K30-35KD-05	Bush ZDS/K30-35KD-05	2	
21	256898526014	销锁紧螺母Z30KD010G	Pin lock nut Z30KD010G	2	
22	256898526015	开口销3.2X50	Pin 3.2X50	2	
23	256898526016	右转向节Z30KD007G	Right knuckle Z30KD007G	1	
24	256898526017	旋转轴唇形密封圈FB85X110X12	Rotary shaft lip seals FB85X110X12	2	
25	256898526018	圆锥滚子轴承30211E	Bearing 30211E	2	
26	256898526019	轮毂螺栓Z30KD013	Hub bolt Z30KD013	16	
27	256898526020	转向轮毂Z30KD011	Steering wheel hub Z30KD011	16	
28	256898526021	轮毂螺母Z30KD012	Wheel hub nut Z30KD012	2	
29	910700600003	圆锥滚子轴承30207	Bearing 30207	2	
30	910400100016	平垫圈30	Washer30	2	

256898501023 仪表罩安装/INSTRUMENT COVER INSTALLATION

序号/NO	编码/SN	名称	Name	数量/QTY	备注/Remark
1	940400400001	板簧螺母M6-t(2-4)	Nut M6	6	
2	256821511006	盖板焊合(右)	Cover assembly	1	
3	910400200002	平垫6	Washer GB97.1-6-200HV	4	
4	941100100009	螺钉M6x12-8.8	Screw M6x12	6	
5	256810021001	仪表罩(30Q)	Instrument mask	1	
6	255010020005	前盖	Cover	1	
7	255010020006	后盖	Cover	1	
8	256810021004	制动液杯盖	Cover	1	
9	256821511004	盖板焊合(左)	Cover assembly	1	

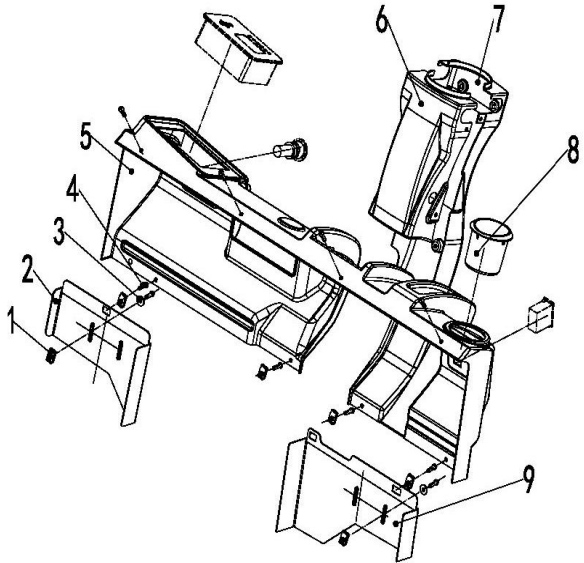

256898501025 脚踏板安装/FOOT PEDAL

序号/NO	编码/SN	名称	Name	数量/QTY	备注/Remark
1	256818021005	地板垫(30Q)	Cushion	2	
2	256818011001	前地板焊合	Floor welding (front)	1	
3	256818011002	后地板焊合	Floor welding (rear)	1	
4	941100100001	螺钉M8X12-8.8	Screw M8x12-8.8	2	
5	256818021006	上车踏板(30Q)	Foot pedal	1	

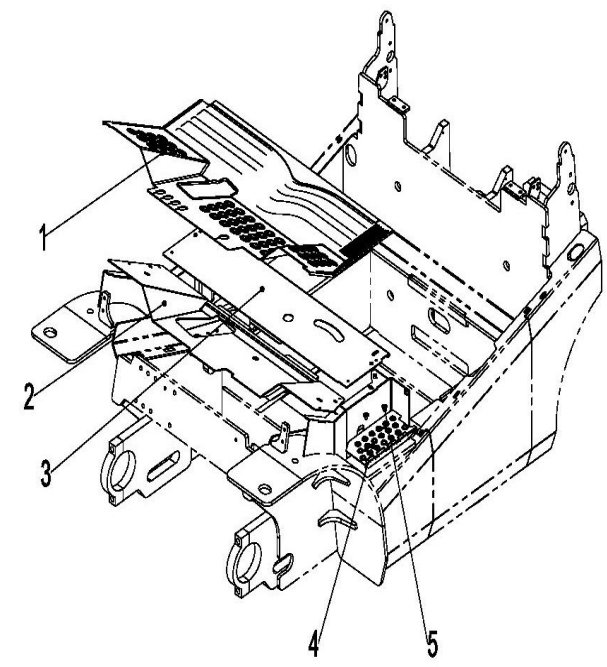

256898501026液压系统/HYDRAULIC

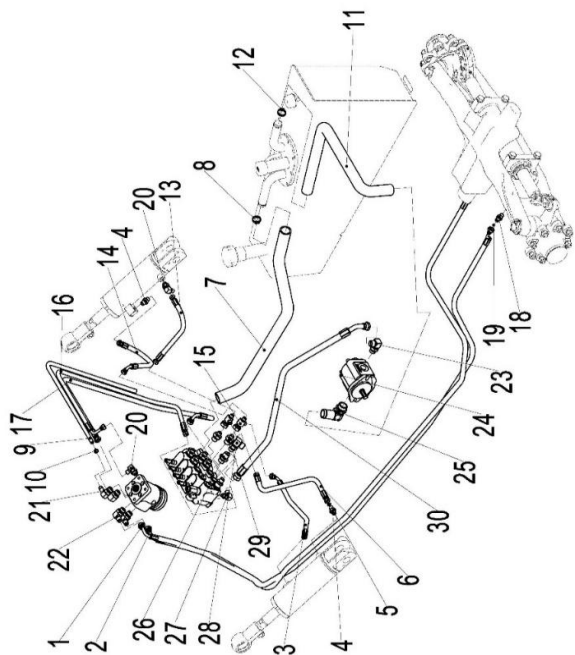

序号/NO	编码/SN	名称	Name	数量/QTY	备注/Remark
1	255023520001	液压管总成(异)8-L3000-1SC-60°	Hydraulic Tube Assembly (Extraordina	1	
2	255023520002	液压管总成(异)8-L2700-1SC-60°	Hydraulic Tube Assembly (Extraordina	1	
3	256823520003	液压管总成(90°)6-L750-1SC-60°	Hydraulic Tube Assembly (90°)6-L750	1	
4	255023520007	接头(直)6-G1/4-M14x1.5-60°	Connector (straight)6-G1/4 M14X1.5-6	3	
5	910800100021	O形圈-内11.2x2.65	O-ring - inside 11.2x2.65	4	
6	275223521006	液压管总成(90°)6-L700-1SC-60°	Hydraulic Tube Assembly (90°)6-L700	1	
7	256923521006	胶管(回油)	Rubber hose (return oil)	1	
8	911000600004	喉箍QC/T390-(34-38)	Hose hoops QC/T390 - - 38 (34)	4	
9	900200401001	回油胶管23x5	Return oil hose 23X5	2560	
10	911000600003	喉箍QC/T390-(22-26)	Hose hoops QC/T390 - (22-26),	2	
11	256923521007	胶管(吸油)	Rubber hose (oil absorption)	1	
12	911000600006	喉箍QC/T390-(40-45)	Hose hoops QC/T390 - (40-45)	2	
13	256823520004	液压管总成(135°)6-L450-1SC-60°	Hydraulic Tube Assembly (135°)6-L45	1	
14	252123520002	液压管总成(135°)6-L600-1SC-60°	Hydraulic Tube Assembly (Straight)6-L	1	
15	255023510012	接头(三通)7-2xM14x1.5-M16x1.5-60°	Connector (tee) 7-2XM14X1.5 - M16X	2	
16	252123520011	液压管总成(90°)6-L1320-1SC-60°	Hydraulic Tube Assembly (90°)6-L132	1	
17	251123521005	液压管总成(90°)8-L1320-1SC-60°	Hydraulic Tube Assembly (90°)8-L132	1	
18	255023520034	接头(直)8-2xM16x1.5-60°	Connector (straight) 8-2XM16X1.5-60	2	
19	910800100002	O形圈-内13.2x2.65	O-ring - inside 13.2x2.65	2	
20	255023510003	接头(锁定弯)6-G1/4-M14x1.5-60°	Connector (lock bend)6-G1/4 M14X1.5	2	
21	255023510008	接头(锁定弯)11-M20x1.5-0	Connector (lock bend)11-M20x1.5-0	1	
22	255023510007	接头(锁定弯)10-M20x1.5-M16x1.5-60°	Connector (lock bend) 10-M20X1.5 -	3	
23	255023520035	接头(锁定弯)12-G1/2-M22x1.5-60°	Connector (lock bend)12-G1/2- M22X	1	
24	255023510006	齿轮泵	The gear pump	1	
25	255023510005	接头(转向弯)25-G1-Φ32	Joint (to bend) 25 - G1 - Φ 32	1	
26	255023520030	接头(直)12-2xM22x1.5-60°	Connector (straight) 12-2XM22X1.5	1	
27	255023510001	接头(锁定弯)6-M12x1.5-M14x1.5-60°	Connector (lock bend) 6-M12X1.5 -	1	
28	255044020143	接头(锁定弯)12-M20x1.5-M22x1.5-60°	Connector (lock bend)12-M20x1.5-M2	1	
29	255023520033	接头(直)8-M20x1.5-M16x1.5-60°	Connector (straight) 8-M20X1.5 - M	1	
30	254123520004	液压管总成(90°)13-L2600-2SC-60°	Hydraulic Tube Assembly (90°)13-L	1	

256898501028 多路换向阀操纵(三联)MULTI-WAY REVERSING VALVE CONTROL (THREE)

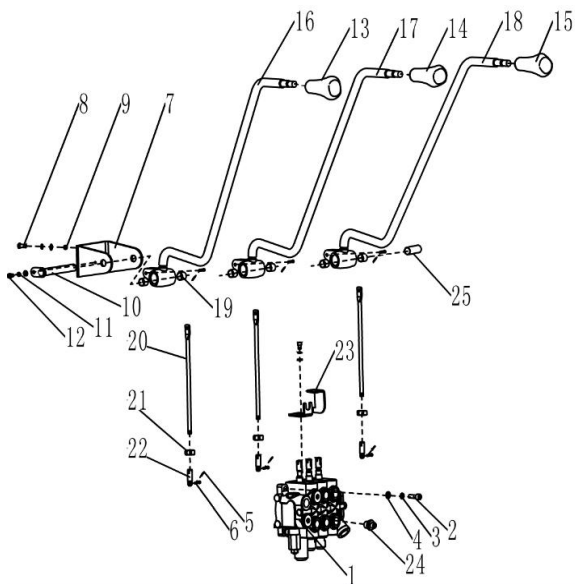

序号/NO	编码/SN	名称	Name	数量/QTY	备注/Remark
1	252025010011	多路阀(三联)	Multiple valve(three)	1	
1	256825011002	多路阀(三联电磁阀ZSX)	Multi way valve (three) solenoid valve	1	CE选配
2	910100400006	螺栓GB5786-M10x1.25x40-8.8	Bolt GB5786-M10x1.25x40-8.8	4	
3	910400500007	弹簧垫圈GB93-10	Spring washer GB93-10	8	
4	910400100007	平垫圈GB97.1-10-200HV	Washer GB97.1-10-200HV	12	
5	941100800001	销轴B4.75x20-c1B	Pin B4.75x20-c1B	6	
6	910600600011	开口销GB91-2x12	Cotter pin GB91-2x12	6	
7	252124520002	支架(阀杆)	Support (stem)	1	
8	910100300037	螺栓GB5783-M10x30-8.8	Bolt GB5783 M10x30-8.8	4	
9	910300100007	螺母GB6170-M10-10	Nut GB6170-M10-10	4	
10	255024510009	带耳轴Φ16x168	With trunnion Φ16x168	1	
11	910400500005	弹簧垫圈GB93-6	Spring washer GB93-6	1	
12	910200200032	螺钉GB70.1-M6x10-8.8	Screw GB70.1 M6x10-8.8	1	
13	253524520010	手柄球(起升)	Handle ball(lift)	1	
14	253524520009	手柄球(倾斜)	Handle ball(tilt)	1	
15	253525020002	手柄球(属具1)	Handle ball(belonging to 1)	1	
16	256824510002	操纵杆焊合(起升)	Joystick welding(lifting)	1	
17	256824510003	操纵杆焊合(倾斜)	Joystick welding(tilt)	1	
18	256825010004	操纵杆焊合(属具1)	Joystick welding(tool1)	1	
19	940500100006	复合套Φ16xΦ18x15-SF-1	Composite setΦ16xΦ18x15-SF-1	6	
20	256824520003	连接杆	Connecting rod	3	
21	910300100006	螺母GB6170-M8-10	Nut GB6170 M8-10	3	
22	255025020003	接头	joint	3	
23	253524520014	支架(行程开关)	Bracket (travel switch)	3	
24	255023520033	接头(直)8-M20x1.5-M16x1.5-60°	Joint (straight) 8-M20x1.5-M16x1.5-60°	2	
25	255024520028	轴套Φ29xΦ16x38	Shaft sleeve Φ16xΦ29x38	1	

256898501029 多路换向阀操纵(四联)MULTI-WAY REVERSING VALVE CONTROL (TOUR)

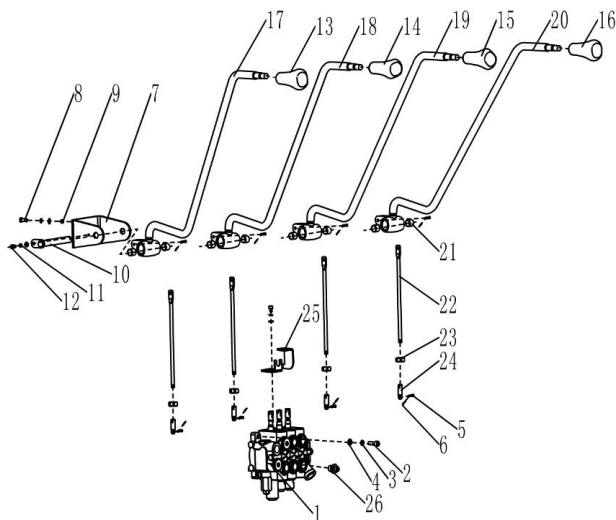

序号/NO	编码/SN	名称	Name	数量/QTY	备注/Remark
1	252025510011	多路阀(四联)	Multiway valve (four)	1	
1	256825511002	多路阀(4联电磁阀ZSX)	Multi way valve (four) solenoid valve	1	CE选配
2	910100400006	螺栓GB5786-M10x1.25x40-8.8	Bolt GB5786-M10x1.25x40-8.8	4	
3	910400500007	弹簧垫圈GB93-10	Spring washer GB93-10	8	
4	910400100007	平垫圈GB97.1-10-200HV	Washer GB97.1-10-200HV	12	
5	941100800001	销轴B4.75x20-c1B	Pin B4.75x20-c1B	8	
6	910600600011	开口销GB91-2x12	Cotter pin GB91-2x12	8	
7	252124520002	支架(阀杆)	Support (stem)	1	
8	910100300037	螺栓GB5783-M10x30-8.8	Bolt GB5783 M10x30-8.8	4	
9	910300100007	螺母GB6170-M10-10	Nut GB6170-M10-10	4	
10	255024510009	带耳轴Φ16x168	With trunnion Φ16x168	1	
11	910400500005	弹簧垫圈GB93-6	Spring washer GB93-6	1	
12	910200200032	螺钉GB70.1-M6x10-8.8	Screw GB70.1 M6x10-8.8	1	
13	253524520010	手柄球(起升)	Handle ball (lift)	1	
14	253524520009	手柄球(倾斜)	Handle ball (tilt)	1	
15	253525020002	手柄球(属具1)	Handle ball (belonging to1)	1	
16	253525520002	手柄球(属具2)	Handball (belonging to 2)	1	
17	256824510002	操纵杆焊合(起升)	Joystick welding (lifting)	1	
18	256824510003	操纵杆焊合(倾斜)	Joystick welding (tilt)	1	
19	256825010004	操纵杆焊合(属具1)	Joystick welding (tool 1)	1	
20	256825510005	操纵杆焊合(属具2)	Joystick welding (kit 2)	1	
21	940500100006	复合套Φ16xΦ18x15-SF-1	Composite set Φ16xΦ18x15-SF-1	8	
22	256824520003	连接杆	Connecting rod	4	
23	910300100006	螺母GB6170-M8-10	Nut GB6170 M8-10	4	
24	255025020003	接头	joint	4	
25	253524520014	支架(行程开关)	Bracket (travel switch)	4	
26	255023520033	接头(直)8-M20x1.5-M16x1.5-60°	Joint (straight)8-M20x1.5-M16x1.5-	4	

256898501032 护顶架装配/TOP GUARD ASSEMBLY

序号/NO	编码/SN	名称	Name	数量/QTY	备注/Remark
1	910200200098	螺钉GB70.1-M12x30-8.8	Screw GB70.1 M12x30-8.8	8	
2	910400500008	弹簧垫圈GB93-12	Spring washer GB93-12	8	
3	910400100008	平垫圈GB97.1-12-200HV	The flat washer GB97.1-12-200HV	4	
4	256822012001	护顶架焊合	The top guard is welded together	1	
5	255022020001	防护罩一(异型管)	Protective cover 1	1	
6	255022020004	尾灯出线圈	Protective tape	4	
7	252022020050	充电插座线垫圈	Protective tape	2	
8	255056510001	后把手开关	Back handle	1	选装
9	910400500005	弹簧垫圈GB93-6	Spring washer GB93-6	2	
10	910200200036	螺钉GB70.1-M6x20-8.8	Screw GB70.1 M6x20-8.8	2	
11	255022020002	防护罩二(异型管)	Protective cover 2	1	
12	255049520010	内后视镜EQ-105	Rearview mirror	3	
13	255049520004	支架(外双镜)	Support	2	
14	910400200005	大垫圈GB96.1-12-200HV	Big washer GB96.1-12-200HV	4	
15	910200200057	螺钉GB70.1-M8x20-8.8	Screw GB70.1 M8x20-8.8	2	
16	910400500006	弹簧垫圈GB93-8	Spring washer GB93-8	2	
17	255022020029	把手	Handle	1	选装
18	910300500004	螺母GB889.1-M8-10	Nut GB889.1-M8-10	4	
19	910100300022	螺栓GB5783-M8x20-8.8	Bolt GB5783 M8x20-8.8	4	
20	255022020003	大灯穿线圈	Protective tape	2	
21	253522020024	孔塞30	Cover 30	4	

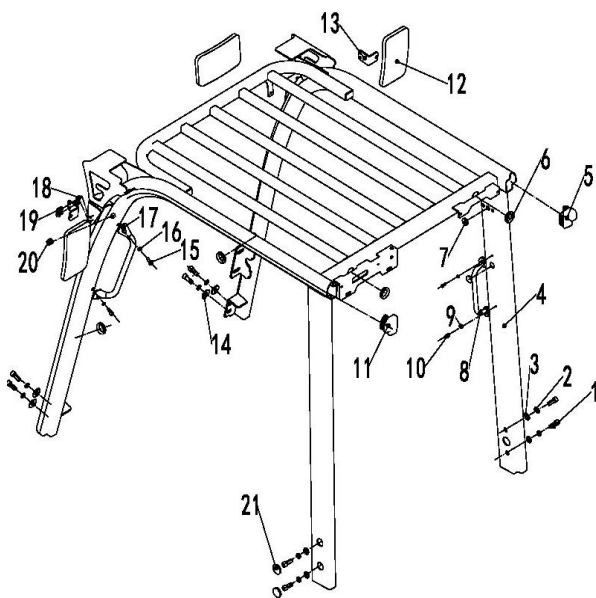

256898501033 货叉/FORK

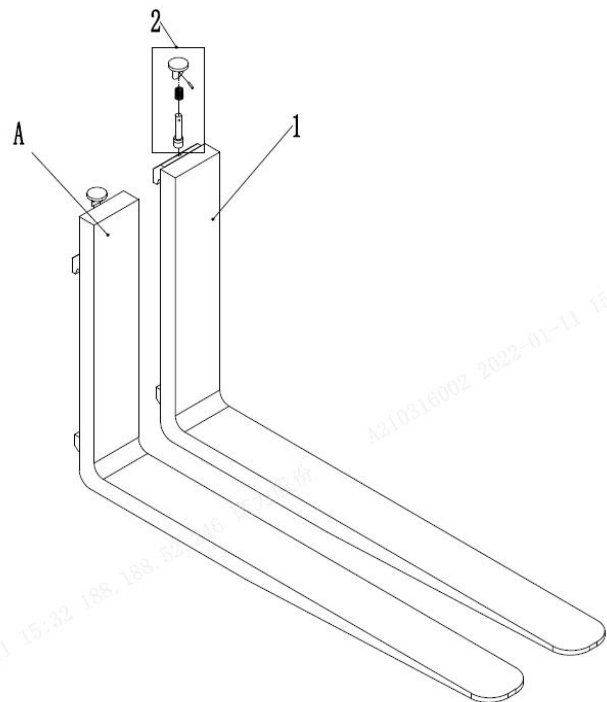

序号/NO	编码/SN	名称	Name	数量/QTY	备注/Remark
A	940100100008	挂钩II A型货叉120x40x1070	Fork 120x40x1070	2	25Q
	940100100010	挂钩II A型货叉120x40x1150	Fork 120x40x1150	2	25Q
	940100100009	挂钩II A型货叉120x40x1220	Fork 120x40x1220	2	25Q
	940100100011	挂钩II A型货叉120x40x1370	Fork 120x40x1370	2	25Q
	940100100012	挂钩II A型货叉120x40x1520	Fork 120x40x1520	2	25Q
	940100100030	挂钩II A型货叉120x40x1820	Fork 120x40x1820	2	25Q
	940100100044	挂钩II A型货叉120x40x1970	Fork 120x40x1970	2	25Q
	940100100046	挂钩II A型货叉120x40x1670	Fork 120x40x1670	2	25Q
A	940100100013	挂钩III A型货叉125x45x1070	Fork 125x45x1070	2	28-30Q
	940100100014	挂钩III A型货叉125x45x1150	Fork 125x45x1150	2	28-30Q
	940100100015	挂钩III A型货叉125x45x1220	Fork 125x45x1220	2	28-30Q
	940100100016	挂钩III A型货叉125x45x1370	Fork 125x45x1370	2	28-30Q
	940100100017	挂钩III A型货叉125x45x1520	Fork 125x45x1520	2	28-30Q
	940100100035	挂钩III A型货叉125x45x1970	Fork 125x45x1970	2	28-30Q
	940100100039	挂钩III A型货叉125x45x1820	Fork 125x45x1820	2	28-30Q
	940100100041	挂钩III A型货叉125x45x1670	Fork 125x45x1670	2	28-30Q
A	940100100018	挂钩III A型货叉125x50x1070	Fork 125x50x1070	2	35Q
	940100100019	挂钩III A型货叉125x50x1150	Fork 125x50x1150	2	35Q
	940100100020	挂钩III A型货叉125x50x1220	Fork 125x50x1220	2	35Q
	940100100021	挂钩III A型货叉125x50x1370	Fork 125x50x1370	2	35Q
	940100100022	挂钩III A型货叉125x50x1520	Fork 125x50x1520	2	35Q
	940100100031	挂钩III A型货叉125x50x1800	Fork 125x50x1800	2	35Q
	940100100040	挂钩III A型货叉125x50x1970	Fork 125x50x1970	2	35Q
	940100100042	挂钩III A型货叉125x50x1670	Fork 125x50x1670	2	
1	▲	货叉体	Fork body	2	
2	253098514101	提销总成	Lift pin assembly	2	

256898501034 倾斜油缸/TILT CYLINDER (30-35Q)

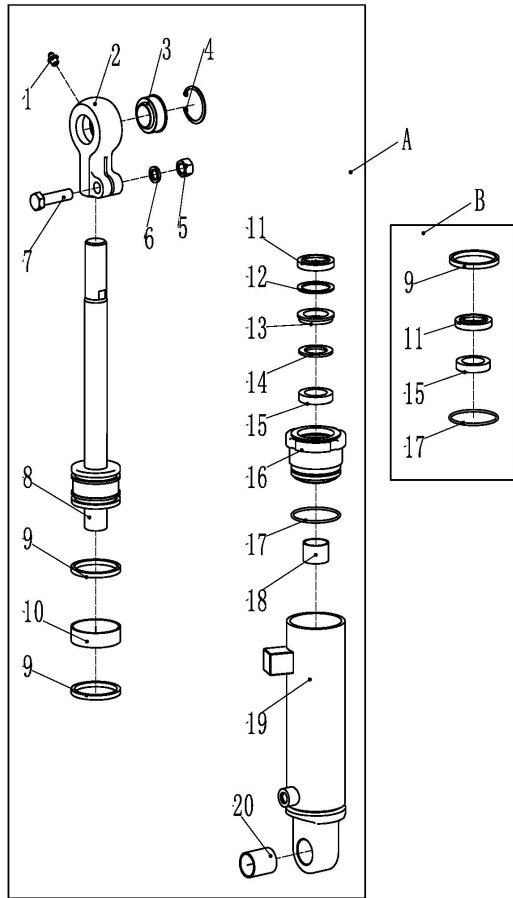

序号/NO	编码/SN	名称	Name	数量/QTY	备注/Remark
A	256820510001	油缸(TL)(TL) Φ80xΦ35x118(6/10)	Oil cylinder(TL)Φ80xΦ35x118(6/10)	1	H≤3700, Left
A	256820510002	油缸(TL)(TL) Φ80xΦ35x88.5(6/6)	Oil cylinder(TL)Φ80xΦ35x88.5(6/6)	1	3700<H≤
A	256820510003	油缸(TL)(TL) Φ80xΦ35x67(6/10)	Oil cylinder(TL)Φ80xΦ35x67(3/6)	1	5000<H, Left
A	256820510005	油缸(TL)(TR) Φ80xΦ35x118(6/10)	Oil cylinder(TR)Φ80xΦ35x118(6/10)	1	H≤3700, Right
A	256820510006	油缸(TL)(TR) Φ80xΦ35x88.5(6/6)	Oil cylinder(TR)Φ80xΦ35x88.5(6/6)	1	3700<H≤
A	256820510007	油缸(TL)(TR) Φ80xΦ35x67(6/10)	Oil cylinder(TR)Φ80xΦ35x67(3/6)	1	5000<H, Right
B	256198510006	密封件修理包(倾斜缸)	Seal kits (tlited cylinder)	2	
1	▲	直通式滑脂嘴Z1/8	Grease mouth Z1/8	2	
2	▲	耳环	Earring	2	
3	▲	关节轴承GE30ES	Bearing GE30ES	2	
4	▲	挡圈47	Circlip 47	2	
5	▲	螺母M14	Nut M14	2	
6	▲	垫圈14	Washer14	2	
7	▲	螺栓M14x55	Bolt M14x55	2	
8	▲	活塞体总成	Piston body assembly	2	
9	▲	Yx型密封圈	Yx seal ring	2	
10	▲	支承环D63x20x2.5	Support ring	2	
11	▲	防尘圈	Dust ring	2	
12	▲	挡圈52	Circlip 52	2	
13	▲	挡圈	Circlip	2	
14	▲	挡片48x30x3	Catch 48x30x3	2	
15	▲	U型密封圈	Useal ring 48x30x10	2	
16	▲	导向套	Guide sleeve	2	
17	▲	O型密封圈	O seal ring 63x3.1	2	
18	▲	钢背轴承3025	Bearing 3025	2	
19	▲	缸筒总成	Cylinder barrel assembly	2	
20	▲	钢背轴承3040	Bearing 3040	2	

256898501036 门架(标准门架25-28Q)/MAST(stand mast25-28Q)

序号/NO	编码/SN	名称	Name	数量/QTY	备注/Remark
1	255038020008	调整套	Adjusting sleeve	4	
2	255038020009	调整垫	Adjustable pad	8	
3	940200200005	侧滚轮 Φ42-CD=68	Side rollerΦ42 - CD = 68	2	
4	910400100007	平垫圈GB97.1-10-200HV	Washer GB97.1-10-200HV	8	
5	910400500007	弹簧垫圈GB93-10	Spring washer GB93-10	8	
6	910100300039	螺栓GB5783-M10x40-8.8	Bolt GB5783 M10x40-8.8	4	
7	910401300020	轴用弹性挡圈GB894.1-40	Elastic retaining ring GB894.1-40 for s	4	
8	940200100020	主滚轮 Φ119.2xΦ55x34	Roller Φ119.2xΦ55x34	4	
8	940200100021	主滚轮 Φ119.6xΦ55x34	Roller Φ119.6xΦ55x34	4	
8	940200100022	主滚轮 Φ120xΦ55x34	Roller Φ120xΦ55x34	4	
9	256744012001	内门架焊合(2000)	Mast (2000)	1	25Q
9	256744012002	内门架焊合(2500)	Mast (2500)	1	25Q
9	256744012003	内门架焊合(3000)	Mast (3000)	1	25Q
9	256744012004	内门架焊合(3300)	Mast (3300)	1	25Q
9	256744012005	内门架焊合(3500)	Mast (3500)	1	25Q
9	256744012006	内门架焊合(3600)	Mast (3600)	1	25Q
9	256744012007	内门架焊合(3700)	Mast (3700)	1	25Q
9	256744012008	内门架焊合(4000)	Mast (4000)	1	25Q
9	256744012009	内门架焊合(4300)	Mast (4300)	1	25Q
9	256744012010	内门架焊合(4500)	Mast (4500)	1	25Q
9	256744012011	内门架焊合(5000)	Mast (5000)	1	25Q
9	256744012012	内门架焊合(5500)	Mast (5500)	1	25Q
9	256744012013	内门架焊合(6000)	Mast (6000)	1	25Q
9	256844012001	内门架焊合(2000)	Mast (2000)	1	28Q
9	256844012002	内门架焊合(2500)	Mast (2500)	1	28Q
9	256844012003	内门架焊合(3000)	Mast (3000)	1	28Q
9	256844012004	内门架焊合(3300)	Mast (3300)	1	28Q
9	256844012005	内门架焊合(3500)	Mast (3500)	1	28Q
9	256844012006	内门架焊合(3600)	Mast (3600)	1	28Q
9	256844012007	内门架焊合(3700)	Mast (3700)	1	28Q
9	256844012008	内门架焊合(4000)	Mast (4000)	1	28Q

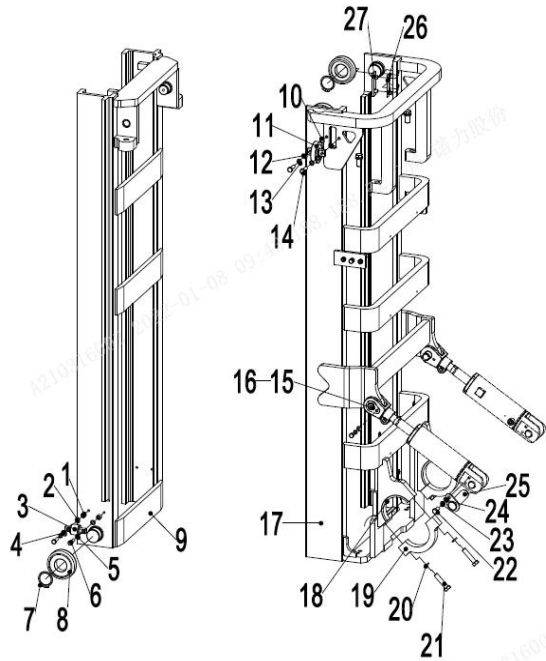

256898501036 门架(标准门架25-28Q)/MAST(stand mast25-28Q)

序号/NO	编码/SN	名称	Name	数量/QTY	备注/Remark
9	256844012009	内门架焊合(4300)	Mast (4300)	1	28Q
9	256844012010	内门架焊合(4500)	Mast (4500)	1	28Q
9	256844012011	内门架焊合(5000)	Mast (5000)	1	28Q
9	256844012012	内门架焊合(5500)	Mast (5500)	1	28Q
9	256844012013	内门架焊合(6000)	Mast (6000)	1	
10	255038020009	调整垫	Adjustable pad	4	
11	940200200002	侧滚轮Φ87-CD=55	Side roller Φ87-CD=55	2	
12	910400100008	平垫圈GB97.1-12-200HV	Washer GB97.1-12-200HV	4	
13	910400500008	弹簧垫圈GB93-12	Washer GB93-12	6	
14	910100300050	螺栓GB5783-M12x30-8.8	Bolt GB5783-M12x30-8.8	4	
15	256844510001	带耳轴Φ30x94	AxleΦ30x94	2	
16	272344021080	耐磨套Φ30xΦ38x25	the wear-proof casing	2	
17	256744011001	外门架焊合(2000)	Mast (2000)	1	
17	256744011002	外门架焊合(2500)	Mast (2500)	1	
17	256744011003	外门架焊合(3000)	Mast (3000)	1	
17	256744011004	外门架焊合(3300)	Mast (3300)	1	
17	256744011005	外门架焊合(3500)	Mast (3500)	1	
17	256744011006	外门架焊合(3600)	Mast (3600)	1	
17	256744011007	外门架焊合(3700)	Mast (3700)	1	
17	256744011008	外门架焊合(4000)	Mast (4000)	1	
17	256744011009	外门架焊合(4300)	Mast (4300)	1	
17	256744011010	外门架焊合(4500)	Mast (4500)	1	
17	256744011011	外门架焊合(5000)	Mast (5000)	1	
17	256744011012	外门架焊合(5500)	Mast (5500)	1	
17	256744011013	外门架焊合(6000)	Mast (6000)	1	
18	254144020063	轴瓦	Bearing bush	2	
19	255044020005	支座盖	Bearing cover	2	
20	910400500010	弹簧垫圈GB93-16	Washer GB93-16	6	
21	910100200016	螺栓GB5785-M16x1.5x70-8.8	Bolt GB5785-M16x1.5x70-8.8	4	
22	910100300035	螺栓GB5783-M10x20-8.8	Bolt GB5783-M10x20-8.8	4	
23	910400100007	平垫圈GB97.1-10-200HV	Washer GB97.1-10-200HV	8	

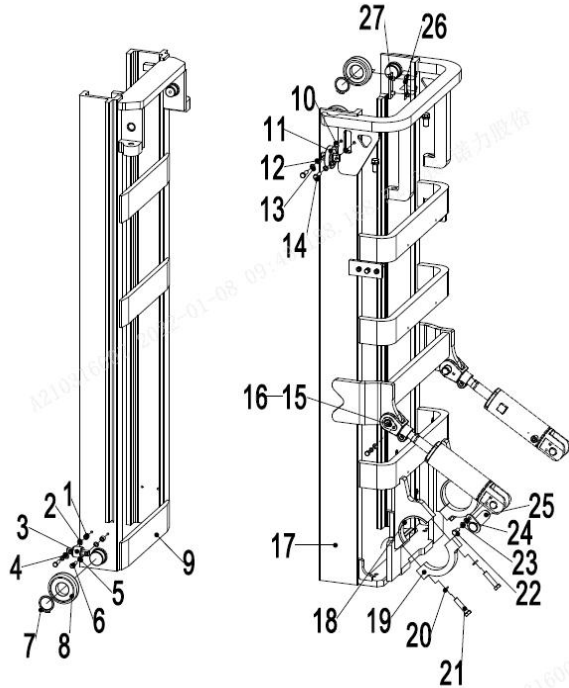

256898501037 门架(标准门架30-35Q)/MAST(stand mast30-35Q)

序号/NO	编码/SN	名称	Name	数量/QTY	备注/Remark
1	255038020008	调整套	Adjusting sleeve	4	
2	255038020009	调整垫	Adjustable pad	8	
3	940200200005	侧滚轮 Φ42-CD=68	Side rollerΦ42 - CD = 68	2	
4	910400100007	平垫圈GB97.1-10-200HV	Washer GB97.1-10-200HV	8	
5	910400500007	弹簧垫圈GB93-10	Spring washer GB93-10	8	
6	910100300039	螺栓GB5783-M10x40-8.8	Bolt GB5783 M10x40-8.8	4	
7	910401300020	轴用弹性挡圈GB894.1-40	Elastic retaining ring GB894.1-40 for s	4	
8	940200100020	主滚轮 Φ119.2xΦ55x34	Roller Φ119.2xΦ55x34	4	
8	940200100021	主滚轮 Φ119.6xΦ55x34	Roller Φ119.6xΦ55x34	4	
8	940200100022	主滚轮 Φ120xΦ55x34	Roller Φ120xΦ55x34	4	
9	256844012001	内门架焊合(2000)	Inner Mast (2000)	1	30Q
9	256844012002	内门架焊合(2500)	Inner Mast (2500)	1	30Q
9	256844012003	内门架焊合(3000)	Inner Mast (3000)	1	30Q
9	256844012004	内门架焊合(3300)	Inner Mast (3300)	1	30Q
9	256844012005	内门架焊合(3500)	Inner Mast (3500)	1	30Q
9	256844012006	内门架焊合(3600)	Inner Mast (3600)	1	30Q
9	256844012007	内门架焊合(3700)	Inner Mast (3700)	1	30Q
9	256844012008	内门架焊合(4000)	Inner Mast (4000)	1	30Q
9	256844012009	内门架焊合(4300)	Inner Mast (4300)	1	30Q
9	256844012010	内门架焊合(4500)	Inner Mast (4500)	1	30Q
9	256844012011	内门架焊合(5000)	Inner Mast (5000)	1	30Q
9	256844012012	内门架焊合(5500)	Inner Mast (5500)	1	30Q
9	256844012013	内门架焊合(6000)	Inner Mast (6000)	1	30Q
9	256844012051	内门架焊合(2000)	Inner mast (2000)	1	35Q
9	256844012052	内门架焊合(2500)	Inner mast (2500)	1	35Q
9	256844012053	内门架焊合(3000)	Inner mast (2700)	1	35Q
9	256844012054	内门架焊合(3300)	Inner mast (3000)	1	35Q
9	256844012055	内门架焊合(3500)	Inner mast (3300)	1	35Q
9	256844012056	内门架焊合(3600)	Inner mast (3500)	1	35Q
9	256844012057	内门架焊合(3700)	Inner mast (3700)	1	35Q
9	256844012058	内门架焊合(4000)	Inner mast (4000)	1	35Q

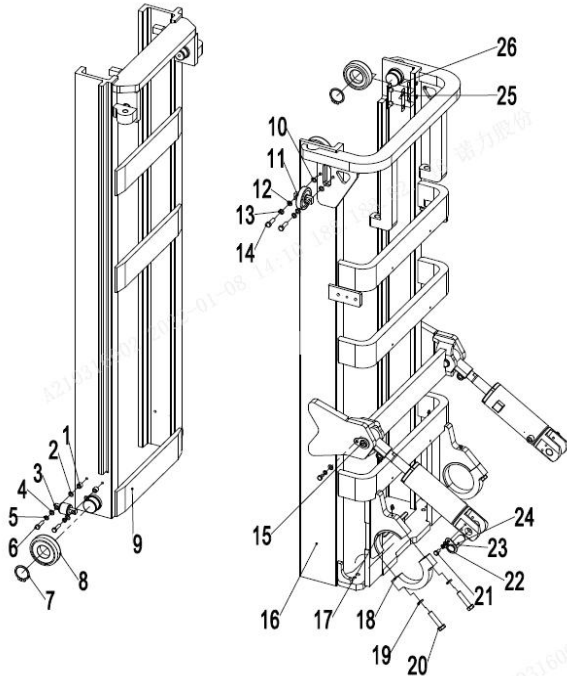

256898501037 门架(标准门架30-35Q)/MAST(stand mast30-35Q)

序号/NO	编码/SN	名称	Name	数量/QTY	备注/Remark
9	256844012059	内门架焊合(4300)	Inner mast(4300)	1	35Q
9	256844012060	内门架焊合(4500)	Inner mast(4500)	1	35Q
9	256844012061	内门架焊合(5000)	Inner mast(5000)	1	35Q
9	256844012062	内门架焊合(5500)	Inner mast(5500)	1	35Q
9	256844012063	内门架焊合(6000)	Inner mast(6000)	1	35Q
10	255038020009	调整垫	Adjustable pad	4	
11	940200200002	侧滚轮Φ87-CD=55	Side roller Φ87-CD=55	2	
12	910400100008	平垫圈GB97.1-12-200HV	Washer GB97.1-12-200HV	4	
13	910400500008	弹簧垫圈GB93-12	Washer GB93-12	6	
14	910100300050	螺栓GB5783-M12x30-8.8	Bolt GB5783-M12x30-8.8	4	
15	256844510001	带耳轴Φ30x94	Outer mast(3600)	1	30Q
16	256844011001	外门架焊合(2000)	Outer mast(2000)	1	30Q
16	256844011002	外门架焊合(2500)	Outer mast(2500)	1	30Q
16	256844011003	外门架焊合(3000)	Outer mast(3000)	1	30Q
16	256844011004	外门架焊合(3300)	Outer mast(3300)	1	30Q
16	256844011005	外门架焊合(3500)	Outer mast(3500)	1	30Q
16	256844011006	外门架焊合(3600)	Outer mast(3600)	1	30Q
16	256844011007	外门架焊合(3700)	Outer mast(3600)	1	30Q
16	256844011008	外门架焊合(4000)	Outer mast(4000)	1	30Q
16	256844011009	外门架焊合(4300)	Outer mast(4300)	1	30Q
16	256844011010	外门架焊合(4500)	Outer mast(4500)	1	30Q
16	256844011011	外门架焊合(5000)	Outer mast(5000)	1	30Q
16	256844011012	外门架焊合(5500)	Outer mast(5500)	1	30Q
16	256844011013	外门架焊合(6000)	Outer mast(6000)	1	30Q
16	256844011051	外门架焊合(2000)	Outer mast(2000)	1	35Q
16	256844011052	外门架焊合(2500)	Outer mast(2500)	1	35Q
16	256844011053	外门架焊合(3000)	Outer mast(3000)	1	35Q
16	256844011054	外门架焊合(3300)	Outer mast(3300)	1	35Q
16	256844011055	外门架焊合(3500)	Outer mast(3500)	1	35Q
16	256844011056	外门架焊合(3600)	Outer mast(3600)	1	35Q
16	256844011057	外门架焊合(3700)	Outer mast(3600)	1	35Q

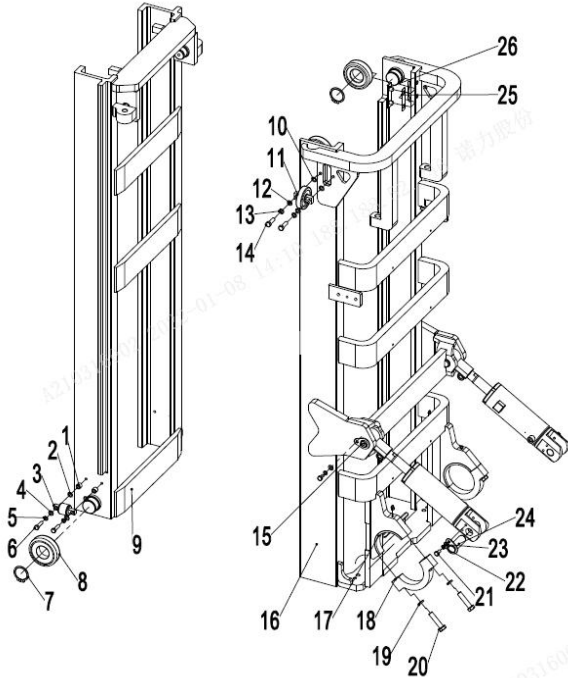

256898501037 门架(标准门架30-35Q)/MAST(stand mast30-35Q)

序号/NO	编码/SN	名称	Name	数量/QTY	备注/Remark
16	256844011058	外门架焊合(4000)	Outer mast(4000)	1	35Q
16	256844011059	外门架焊合(4300)	Outer mast(4300)	1	35Q
16	256844011060	外门架焊合(4500)	Outer mast(4500)	1	35Q
16	256844011061	外门架焊合(5000)	Outer mast(5000)	1	35Q
16	256844011062	外门架焊合(5500)	Outer mast(5500)	1	
16	256844011063	外门架焊合(6000)	Outer mast(6000)	1	
17	254144020063	轴瓦	Bearing bush	2	
18	255044020005	支座盖	Bearing cover	2	
19	910400500010	弹簧垫圈GB93-16	Washer GB93-16	6	
20	910100200016	螺栓GB5785-M16x1.5x70-8.8	Bolt GB5785-M16x1.5x70-8.8	4	
21	910100300035	螺栓GB5783-M10x20-8.8	Bolt GB5783-M10x20-8.8	4	
22	910400100007	平垫圈GB97.1-10-200HV	Washer GB97.1-10-200HV	8	
23	910400500007	弹簧垫圈GB93-10	Washer GB93-10	8	
24	255044010057	带耳轴Φ30x82	AxleΦ30x82	2	
25	255044020132	调整垫片t=0.8	Adjusting pad t=0.8	2	
25	255044020133	调整垫片t=0.5	Adjusting pad t=0.5	2	
25	255044020134	调整垫片t=0.2	Adjusting pad t=0.2	2	
26	255044020131	垫板	Base plate	2	

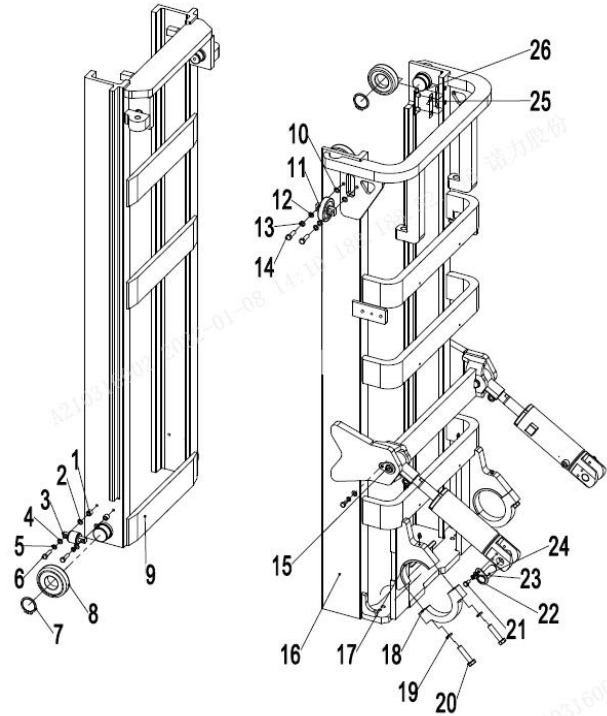

256898501039 起升油缸 (标准门架) /LIFTING PIPE (stand mast)

序号/NO	编码/SN	名称	Name	数量/QTY	备注/Remark	
1	940200500005	链轮轴承780708K-φ110xφ40x27	Chain wheel bearing780708K-φ110xφ	2		
2	910401300020	轴用弹性挡圈GB894.1-40	Circlip GB894.1-40	2		
3	910400500010	弹簧垫圈GB93-16	Washer GB93-16	4		
4	910100400029	螺栓GB5786-M16x1.5x40-8.8	Bolt GB5786-M16x1.5x40-8.8	2		
5	255044010043	油缸 (H=2000)	Cylinder φ56xφ45x995(H=2000)	2	25Q	
5	255044010044	油缸 (H=2500)	Cylinder φ56xφ45x1245(H=2500)	2		
5	255044010055	油缸 (H=3000)	Cylinder φ56xφ45x1495(H=3000)	2		
5	255044010045	油缸 (H=3300)	Cylinder φ56xφ45x1645(H=3300)	2		
5	255044010046	油缸 (H=3500)	Cylinder φ56xφ45x1745(H=3500)	2		
5	255044010047	油缸 (H=3600)	Cylinder φ56xφ45x1795(H=3600)	2		
5	255044010048	油缸 (H=3700)	Cylinder φ56xφ45x1845(H=3700)	2		
5	255044010049	油缸 (H=4000)	Cylinder φ56xφ45x2045(H=4000)	2		
5	255044010050	油缸 (H=4300)	Cylinder φ56xφ45x2195(H=4300)	2		
5	255044010051	油缸 (H=4500)	Cylinder φ56xφ45x2295(H=4500)	2		
5	255044010052	油缸 (H=5000)	Cylinder φ56xφ45x2595(H=5000)	2		
5	255044010053	油缸 (H=5500)	Cylinder φ56xφ45x2845(H=5500)	2		
5	255044010054	油缸 (H=6000)	Cylinder φ56xφ45x3095(H=6000)	2		
5	256044016001	油缸 (H=2000)	Cylinder φ56xφ45x995(H=2000)	2		28Q/30Q/35Q
5	256044016002	油缸 (H=2500)	Cylinder φ56xφ45x1245(H=2500)	2		
5	256044016003	油缸 (H=3000)	Cylinder φ56xφ45x1495(H=3000)	2		
5	256044016004	油缸 (H=3300)	Cylinder φ56xφ45x1645(H=3300)	2		
5	256044016005	油缸 (H=3500)	Cylinder φ56xφ45x1745(H=3500)	2		
5	256044016006	油缸 (H=3600)	Cylinder φ56xφ45x1825(H=3600)	2		
5	256044016007	油缸 (H=3700)	Cylinder φ56xφ45x1845(H=3700)	2		
5	256044016008	油缸 (H=4000)	Cylinder φ56xφ45x1995(H=4000)	2		
5	256044016009	油缸 (H=4300)	Cylinder φ56xφ45x2120(H=4300)	2		
5	256044016010	油缸 (H=4500)	Cylinder φ56xφ45x2245(H=4500)	2		
5	256044016011	油缸 (H=5000)	Cylinder φ56xφ45x2495(H=5000)	2		
5	256044016012	油缸 (H=5500)	Cylinder φ56xφ45x2745(H=5500)	2		
5	256044016013	油缸 (H=6000)	Cylinder φ56xφ45x2995(H=6000)	2		
6	910600600022	开口销GB91-2.5x40	Split pin 2.5x40	2		

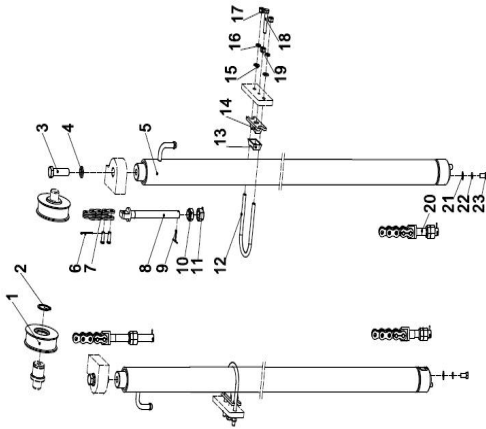
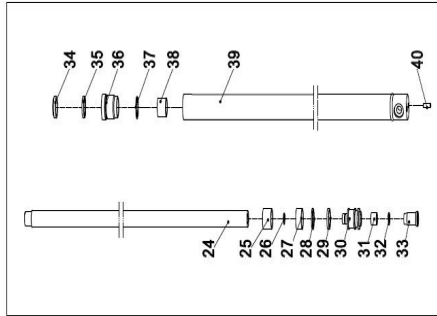

256898501039 起升油缸（标准门架）/LIFTING PIPE (stand mast)

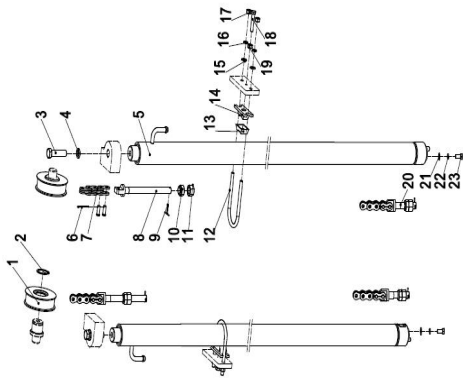
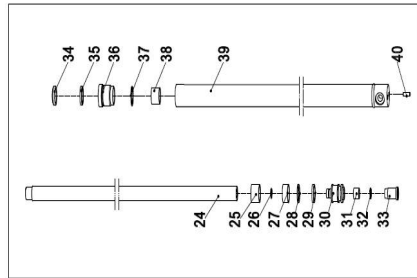

序号/NO	编码/SN	名称	Name	数量/QTY	备注/Remark
7	910900400014	板式链GB6074-LH1623	LH1623 chain	2	25Q/28Q/30Q
7	910900400015	板式链GB6074-LH1634	LH1634 chain	2	35Q
8	255044020157	链条螺栓M18x1.5x217	Joint	2	25Q/28Q/30Q
8	254044020062	链条螺栓M20x1.5x224	Joint	2	35Q
9	910300600030	开口销GB91-3.2x30	Split pin 3.2x30	2	
10	255044020158	球面螺母M18x1.5	Nut M18x1.5	2	25Q/28Q/30Q
10	910300800002	螺母GB812-M20x1.5	Nut M20x1.5	2	35Q
11	910300400007	螺母GB6173-M18x1.5-05	Nut M18x1.5	2	25Q/28Q/30Q
11	255013520002	螺母M20x1.5	Nut M20x1.5	2	35Q
12	255044020128	U形螺栓Φ68	Fixing ring	2	
13	255044020129	防护罩	Rubber bushing	2	
14	255044020130	固定座（油缸）	Fixing seat	2	
15	910400100007	平垫圈GB97.1-16-200HV	Washer GB97.1-16-200HV	4	
16	910400500007	弹簧垫圈GB93-10	Washer GB93-10	4	
17	910300200002	螺母GB6171-M10x1.25-10	Nut GB6171-M10x1.25-10	4	
18	910100300041	螺栓GB5783-M10x50-8.8	Bolt GB5783-M10x50-8.8	2	
19	910300100007	螺母GB6170-M10-10	Nut GB6170-M10-10	2	
20	255044020156	链条螺栓M18x1.5x102	Joint	2	25Q/28Q/30Q
20	254044020064	链条螺栓M20x1.5x124	Joint	2	35Q
21	910400100008	平垫圈GB97.1-12-200HV	Washer GB97.1-12-200HV	2	
22	910400500008	弹簧垫圈GB93-12	Washer GB93-12	2	
23	910100400009	螺栓GB5786-M12x1.25x25-8.8	Bolt GB5786-M12x1.25x25-8.8	2	
24	▲	活塞杆	Piston rod	1	
25	▲	调整套40.5x49xL2	Adjusting bushing 40.5x49xL2	1	
26	▲	钢丝挡圈	Circlip	1	
27	▲	支承环56x20x2.5	Bearing 50x20x2.5	1	
28	▲	挡片56x45x3	Catch 50x40x3	1	
29	▲	孔用密封圈	Seal ring 50x40x6	1	
30	▲	活塞	Piston rod	1	
31	▲	铜套	Copper bushing	1	
32	▲	钢丝挡圈	Circlip	1	

256898501039 起升油缸 (标准门架) /LIFTING PIPE (stand mast)

序号/NO	编码/SN	名称	Name	数量/QTY	备注/Remark
33	▲	缓冲环	Buffering ring	1	
34	▲	防尘圈	Dust ringDKB40x52x7/10	1	
35	▲	轴用密封圈	Seal ring 40x50x6	1	
36	▲	导向套	Guide sleeve	1	
37	▲	O型密封圈	O ring 49.7x2.4	1	
38	▲	钢背轴承4530	Bearing 4030	1	
39	▲	缸体	Cylinder	1	
40	▲	圆柱销D10x26	Dowel pin	1	
41	256098510001	密封件修理包(标准门架起升缸)	Seal kits(standard mast lifting cylinder)	2	包含/Inc.
A	255043510139	起升链条LH1623-79/H=3000	Lifting chain LH1623-77	2	25Q/28Q/30Q
	255044510133	起升链条LH1623-59/H=2000	Lifting chain LH1623-57	2	
	255043510085	起升链条LH1623-69/H=2500	Lifting chain LH1623-67	2	
	255044510140	起升链条LH1623-85/H=3300	Lifting chain LH1623-83	2	
	255043510088	起升链条LH1623-89/H=3500	Lifting chain LH1623-87	2	
	255044010107	起升链条LH1623-91/H=3600	Lifting chain LH1623-89	2	
	253543510066	起升链条LH1623-93/H=3700	Lifting chain LH1623-91	2	
	255043510107	起升链条LH1623-101/H=4000	Lifting chain LH1623-99	2	
	253544510027	起升链条LH1623-107/H=4300	Lifting chain LH1623-105	2	
	255043510090	起升链条LH1623-111/H=4500	Lifting chain LH1623-109	2	
	253511010064	起升链条LH1623-121/H=5000	Lifting chain LH1623-121	2	
	256044014001	起升链条LH1623-133/H=5500	Lifting chain LH1623-131	2	
	256044014002	起升链条LH1623-143/H=6000	Lifting chain LH1623-141	2	
	A	263044510025	起升链条LH1634-59/H=2000	Lifting chain LH1634-59	2
256144014001		起升链条LH1634-69/H=2500	Lifting chain LH1634-69	2	
263044010042		起升链条LH1634-79/H=3000	Lifting chain LH1634-79	2	
263043510065		起升链条LH1634-85/H=3300	Lifting chain LH1634-85	2	
263044510006		起升链条LH1634-89/H=3500	Lifting chain LH1634-89	2	
254044010057		起升链条LH1634-91/H=3600	Lifting chain LH1634-91	2	
254044010058		起升链条LH1634-93/H=3700	Lifting chain LH1634-93	2	
254044510027		起升链条LH1634-101/H=4000	Lifting chain LH1634-101	2	
	263044510008	起升链条LH1634-107/H=4300	Lifting chain LH1634-107	2	

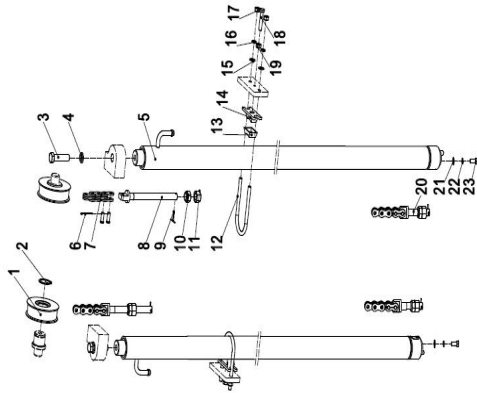
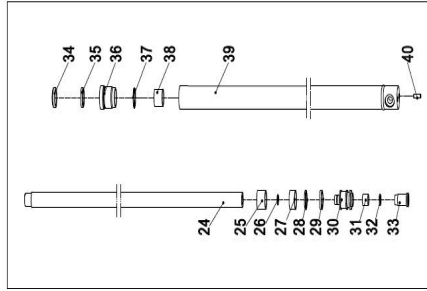

256898501040 门架起升管路 (标准门架) /SINGLE ADDITIONAL TUBE(stand mast)

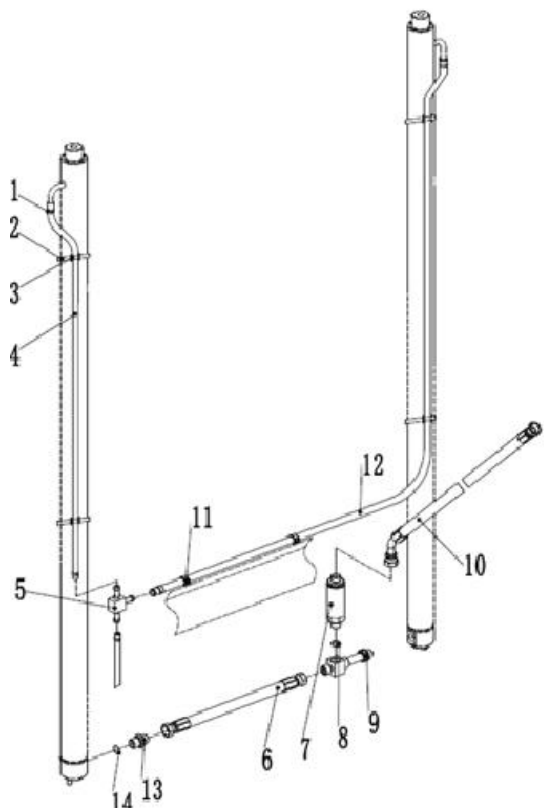

序号/NO	编码/SN	名称	Name	数量/QTY	备注/Remark
1	255044020043	卡箍	Hoop	1	
2	921600400001	扎带4x250	Strip 4x250	1	
3	255044020042	压板	Press plate	1	
4	▲	回油管1L=620	Oil return hose1L=620	2	H=2000
4	▲	回油管1L=870	Oil return hose1L=870	2	H=2500
4	▲	回油管1L=1120	Oil return hose1L=1120	2	H=3000
4	▲	回油管1L=1270	Oil return hose1L=1270	2	H=3300
4	▲	回油管1L=1370	Oil return hose1L=1370	2	H=3500
4	▲	回油管1L=1420	Oil return hose1L=1420	2	H=3600
4	▲	回油管1L=1470	Oil return hose1L=1470	2	H=3700
4	▲	回油管1L=1620	Oil return hose1L=1620	2	H=4000
4	▲	回油管1L=1770	Oil return hose1L=1770	2	H=4300
4	▲	回油管1L=1920	Oil return hose1L=1920	2	H=4500
4	▲	回油管1L=2120	Oil return hose1L=2120	2	H=5000
4	▲	回油管1L=2370	Oil return hose1L=2370	2	H=5500
4	▲	回油管1L=2620	Oil return hose1L=2620	2	H=6000
5	255044020118	接头(三通)	Joint	1	
6	255044020150	液压管总成(直)15-L360-2SC-60°	Hydraulic hose assembly 15-L360-2SC	1	
7	950700300003	限速阀XSF-F16L-60	Speed limit valve XSF-F16L-60	1	
8	910800100040	O形圈-外24x2.4	Oring 24x2.4	1	
9	255044010040	接头(三通)	Joint	1	
10	252144029001	液压管总成(135°)15-L850-2SC-60°	Hydraulic hose assembly(135°)15-L	1	
11	921600400003	扎带(带扣)P-N156-00646	Strip P-N156-00646	2	
12	▲	回油管2	Oil return hose2	1	
13	256898520001	防爆阀	explosion-proof valve	1	
14	910800100003	O形圈-内17x2.65	Oring 17x2.65	3	

256898501041 单附加管路(标准门架)SINGLE ADDITIONAL TUBE(stand mast)

序号/NO	编码/SN	名称	Name	数量/QTY	备注/Remark
1	910100100056	螺栓GB5782-M12x90-8.8	Bolt GB5782-M12x90-8.8	1	
2	910400500008	弹簧垫圈GB93-12	WasherGB93-12	1	
3	910400100008	平垫圈GB97.1-12-200HV	Washer GB97.1-12-200HV	1	
4	255030520022	衬套Φ22xΦ13x56	Bush Φ22xΦ13x56	1	
5	255030520021	滑轮Φ110x27(单槽)	Pulley Φ110x27	2	
6	910200200059	螺钉GB70.1-M8x30-8.8	ScrewGB70.1-M8x30-8.8	2	
7	910400500006	弹簧垫圈GB93-8	Washer GB93-8	6	
8	255028520034	胶管固定块	Rubber pipe lump	2	
9	255028520035	管夹安装板	Pipe press fixedly piank	2	
10	255029020022	液压管总成(90°)10-L3050-1SC-60°	Hydraulic hose assembly (90°) 10-L	2	H=2000
10	254127520004	液压管总成(90°)10-L3500-1SC-60°	Hydraulic hose assembly (90°) 10-L	2	H=2500
10	263028520035	液压管总成(90°)10-L4150-1SC-60°	Hydraulic hose assembly (90°) 10-L	2	H=3000
10	253528520029	液压管总成(90°)10-L4350-1SC-60°	Hydraulic hose assembly (90°) 10-L	2	H=3300
10	255027520001	液压管总成(90°)10-L4500-1SC-60°	Hydraulic hose assembly (90°) 10-L	2	H=3500
10	253530520006	液压管总成(90°)10-L4700-1SC-60°	Hydraulic hose assembly (90°) 10-L	2	H=3700
10	253528520033	液压管总成(90°)10-L5150-1SC-60°	Hydraulic hose assembly (90°) 10-L	2	H=4000
10	256027520001	液压管总成(90°)10-L5450-1SC-60°	Hydraulic hose assembly (90°) 10-L	2	H=4300
10	252027520025	液压管总成(90°)10-L5600-1SC-60°	Hydraulic hose assembly (90°) 10-L	2	H=4500
10	256027520002	液压管总成(90°)10-L6250-1SC-60°	Hydraulic hose assembly (90°) 10-L	2	H=5000
10	256027520003	液压管总成(90°)10-L6750-1SC-60°	Hydraulic hose assembly (90°) 10-L	2	H=5500
10	256027520004	液压管总成(90°)10-L7250-1SC-60°	Hydraulic hose assembly (90°) 10-L	2	H=6000
11	255029020024	接头(锁定弯)8-2xM16x1.5-60°	Joint 8-2XM16x1.5-60°	2	
12	254127520001	安装板	fixedly piank	1	
13	910400100006	平垫圈GB97.1-8-200HV	Washer GB97.1-8-200HV	2	
14	910800100001	O形圈-内9.5x1.8	O ring 9.5x1.8	4	
15	255042520101	液压管总成(90°)10-L500-1SC-60°	Hydraulic hose assembly (90°) 10-L	2	
16	256042510004	外置侧移器1100(LH)	Sideshifters (LH)	1	
16	253542510001	外置侧移器1100(LD)	Sideshifters (LD)	1	
16	256042510002	侧移器总成(卡斯卡特)	Sideshifters (CASCADE)	1	

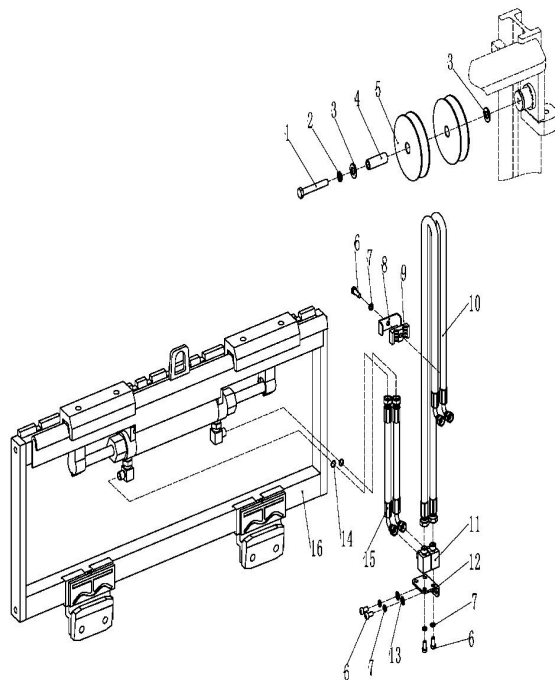

256898501042 双附加管路(标准门架)DOUBLE ADDITIONAL TUBE(stand mast)

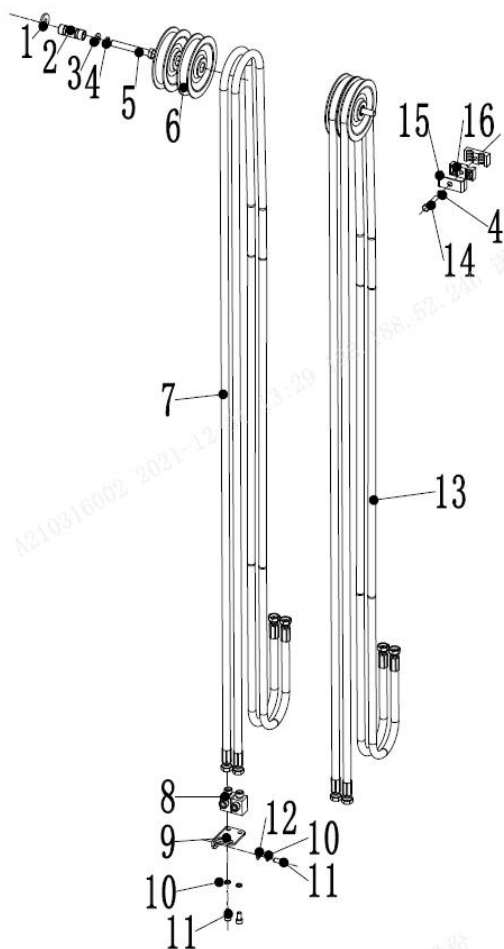

序号/NO	编码/SN	名称	Name	数量/QTY	备注/Remark
1	910400200005	大垫圈GB96.1-12-200HV	Big Washer GB96.1-12-200HV	4	
2	255030520022	衬套Φ22xΦ13x56	Bush Φ22xΦ13x56	2	
3	910400100008	平垫圈GB97.1-12-200HV	washer GB97.1-12-200HV	2	
4	910400500008	弹簧垫圈GB93-12	Spring washer GB93-12	12	
5	910100100056	螺栓GB5782-M12x90-8.8	Bolt GB5782-M12x90-8.8	2	
6	255030520021	滑轮Φ110x27(单槽)	Pulley Φ110x27	4	
7	255029020022	液压管总成(90°)10-L3050-1SC-60°	Hydraulic hose assembly (90°) 10-L	2	H=2000
7	254127520004	液压管总成(90°)10-L3500-1SC-60°	Hydraulic hose assembly (90°) 10-L	2	H=2500
7	263028520035	液压管总成(90°)10-L4150-1SC-60°	Hydraulic hose assembly (90°) 10-L	2	H=3000
7	253528520029	液压管总成(90°)10-L4350-1SC-60°	Hydraulic hose assembly (90°) 10-L	2	H=3300
7	255027520001	液压管总成(90°)10-L4500-1SC-60°	Hydraulic hose assembly (90°) 10-L	2	H=3500
7	253530520006	液压管总成(90°)10-L4700-1SC-60°	Hydraulic hose assembly (90°) 10-L	2	H=3700
7	253528520033	液压管总成(90°)10-L5150-1SC-60°	Hydraulic hose assembly (90°) 10-L	2	H=4000
7	256027520001	液压管总成(90°)10-L5450-1SC-60°	Hydraulic hose assembly (90°) 10-L	2	H=4300
7	252027520025	液压管总成(90°)10-L5600-1SC-60°	Hydraulic hose assembly (90°) 10-L	2	H=4500
7	256027520002	液压管总成(90°)10-L6250-1SC-60°	Hydraulic hose assembly (90°) 10-L	2	H=5000
7	256027520003	液压管总成(90°)10-L6750-1SC-60°	Hydraulic hose assembly (90°) 10-L	2	H=5500
7	256027520004	液压管总成(90°)10-L7250-1SC-60°	Hydraulic hose assembly (90°) 10-L	2	H=6000
8	255029020024	接头(锁定弯)8-2xM16x1.5-60°	Joint 8-2xM16x1.5-60°	4	
9	254127520001	安装板	Plate	2	
10	910400500006	弹簧垫圈GB93-8	Spring washer GB93-8	12	
11	910200200055	螺钉GB70.1-M8x16-8.8	Screw GB70.1-M8x16-8.8	8	
12	910400100006	平垫圈GB97.1-8-200HV	Washer GB97.1-8-200HV	4	
13	256028020001	液压管总成(直)10-L3400-1SC-60°	Hydraulic hose assembly 10-L3400-1	2	H=2000
13	254131020010	液压管总成(直)10-L3850-1SC-60°	Hydraulic hose assembly 10-L3850-1	2	H=2500
13	281227511004	液压管总成(直)10-L4500-1SC-60°	Hydraulic hose assembly 10-L4500-1	2	H=3000
13	275227511002	液压管总成(直)10-L4700-1SC-60°	Hydraulic hose assembly 10-L4700-1	2	H=3300
13	256028020004	液压管总成(直)10-L4850-1SC-60°	Hydraulic hose assembly 10-L4850-1	2	H=3500
13	256028020005	液压管总成(直)10-L5050-1SC-60°	Hydraulic hose assembly 10-L5050-1	2	H=3600/3700
13	281227511007	液压管总成(直)10-L5500-1SC-60°	Hydraulic hose assembly 10-L5500-1	2	H=4000
13	256028020007	液压管总成(直)10-L5800-1SC-60°	Hydraulic hose assembly 10-L5800-1	2	H=4300

256898501043 门架(三级全自由门架)/MAST (three stage full free)

序号/NO	编码/SN	名称	Name	数量/QTY	备注/Remark
1	910100300039	螺栓GB5783-M10x40-8.8	Bolt GB5783-M10x40-8.8	4	
2	910400500007	弹簧垫圈GB93-10	Washer GB93-10	8	
3	910400100007	平垫圈GB97.1-10-200HV	Washer GB97.1-10-200HV	4	
4	255038020009	调整垫	Adjustable pad	8	
5	255038020008	调整套	Adjusting sleeve	4	
6	940200200005	侧滚轮Φ42-CD=68	Side rollerΦ42 - CD = 68	2	
7	910401300024	轴用弹性挡圈	Elastic retaining ring for shaft	4	
8	940200100024	主滚轮Φ111xΦ55x32	RollerΦ111xΦ55x32	4	
8	940200100025	主滚轮Φ111.5xΦ55x32	RollerΦ111.5xΦ55x32	4	
9	256844512001	内门架焊合 3600	Inner mast 3600	1	
9	256844512002	内门架焊合 4000	Inner mast 4000	1	
9	256844512003	内门架焊合 4350	Inner mast 4350	1	
9	256844512004	内门架焊合 4500	Inner mast 4500	1	
9	256844512005	内门架焊合 4700	Inner mast 4700	1	
9	256844512006	内门架焊合 4800	Inner mast 4800	1	
9	256844512007	内门架焊合 5000	Inner mast 5000	1	
9	256844512008	内门架焊合 5400	Inner mast 5400	1	
9	256844512009	内门架焊合 5500	Inner mast 5500	1	
9	256844512010	内门架焊合 6000	Inner mast 6000	1	
9	256844512011	内门架焊合 6500	Inner mast 6500	1	
10	256844513001	中门架焊合 3600	Middle mast 3600	1	
10	256844513002	中门架焊合 4000	Middle mast 4000	1	
10	256844513003	中门架焊合 4350	Middle mast 4350	1	
10	256844513004	中门架焊合 4500	Middle mast 4500	1	
10	256844513005	中门架焊合 4700	Middle mast 4700	1	
10	256844513006	中门架焊合 4800	Middle mast 4800	1	
10	256844513007	中门架焊合 5000	Middle mast 5000	1	
10	256844513008	中门架焊合 5400	Middle mast 5400	1	
10	256844513009	中门架焊合 5500	Middle mast 5500	1	
10	256844513010	中门架焊合 6000	Middle mast 6000	1	
10	256844513011	中门架焊合 6500	Middle mast 6500	1	

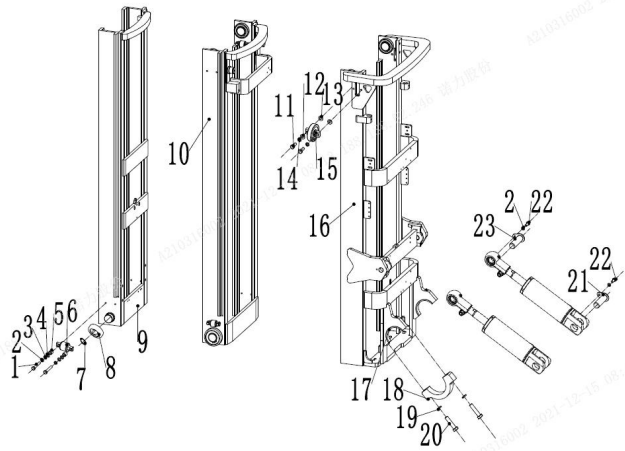

256898501043 门架(三级全自由门架)/MAST (three stage full free)

序号/NO	编码/SN	名称	Name	数量/QTY	备注/Remark
11	910100300050	螺栓GB5783-M12x30-8.8	Bolt GB5783-M12x30-8.8	8	
12	910400100008	平垫圈GB97.1-12-200HV	Washer GB97.1-12-200HV	8	
13	256544002001	垫圈Φ20xΦ13集合图	Washer Φ20xΦ13	8	
14	910400500008	弹簧垫圈GB93-12	Washer GB93-12	8	
15	940200200002	侧滚轮Φ87-CD=55	Side roller Φ87-CD=55	4	
16	256844511001	外门架焊合 3600	Outer mast 3600	1	30Q/35Q
16	256844511002	外门架焊合 4000	Outer mast 4000	1	30Q/35Q
16	256844511003	外门架焊合 4350	Outer mast 4350	1	30Q/35Q
16	256844511004	外门架焊合 4500	Outer mast 4500	1	30Q/35Q
16	256844511005	外门架焊合 4700	Outer mast 4700	1	30Q/35Q
16	256844511006	外门架焊合 4800	Outer mast 4800	1	30Q/35Q
16	256844511007	外门架焊合 5000	Outer mast 5000	1	30Q/35Q
16	256844511008	外门架焊合 5400	Outer mast 5400	1	30Q/35Q
16	256844511009	外门架焊合 5500	Outer mast 5500	1	30Q/35Q
16	256844511010	外门架焊合 6000	Outer mast 6000	1	30Q/35Q
16	256844511011	外门架焊合 6500	Outer mast 6500	1	30Q/35Q
16	256744511001	外门架焊合 3600	Outer mast 3600	1	25Q/28Q
16	256744511002	外门架焊合 4000	Outer mast 4000	1	25Q/28Q
16	256744511003	外门架焊合 4350	Outer mast 4350	1	25Q/28Q
16	256744511004	外门架焊合 4500	Outer mast 4500	1	25Q/28Q
16	256744511005	外门架焊合 4700	Outer mast 4700	1	25Q/28Q
16	256744511006	外门架焊合 4800	Outer mast 4800	1	25Q/28Q
16	256744511007	外门架焊合 5000	Outer mast 5000	1	25Q/28Q
16	256744511008	外门架焊合 5400	Outer mast 5400	1	25Q/28Q
16	256744511009	外门架焊合 5500	Outer mast 5500	1	25Q/28Q
16	256744511010	外门架焊合 6000	Outer mast 6000	1	25Q/28Q
16	256744511011	外门架焊合 6500	Outer mast 6500	1	25Q/28Q
17	254144020063	轴瓦	Bearing bush	2	
18	256844021014	支座盖	Bearing cover	2	
19	910400500010	弹簧垫圈GB93-16	Washer GB93-16	7	
20	910100200016	螺栓GB5785-M16x1.5x70-8.8	Bolt GB5785-M16x1.5x70-8.8	4	

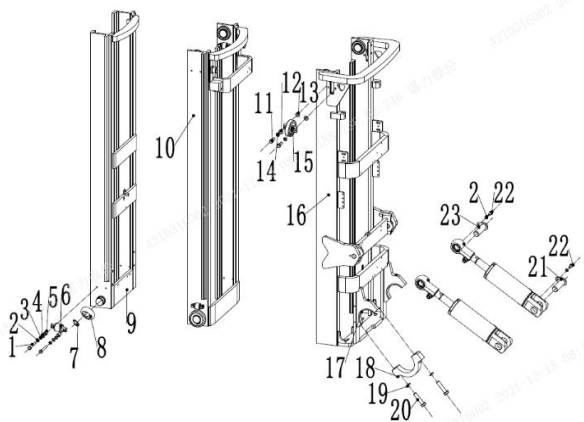

256898501043 门架(三级全自由门架)/MAST (three stage full free)

序号/NO	编码/SN	名称	Name	数量/QTY	备注/Remark
21	255044010057	带耳轴 $\Phi 30 \times 82$	Axle $\Phi 30 \times 82$	4	
22	910100300035	螺栓 GB5783-M10 \times 20-8.8	Bolt GB5783-M10 \times 20-8.8	4	
23	256844501001	带耳轴 $\Phi 30 \times 94$	Axle $\Phi 30 \times 94$	2	

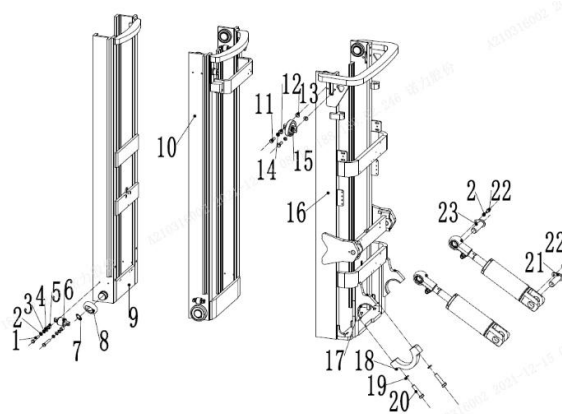

256898501045 短起升油缸(三级全自由门架)/SHORT LIFTING CYLINDER (three stage full free)

序号/NO	编码/SN	名称	Name	数量/QTY	备注/Remark
A	256144518001	油缸(M) Φ85xΦ60x622 (H=3600)	Short lifting cylinderΦ85xΦ60x622 (H=	1	28Q/30Q/35Q
A	256144518002	油缸(M) Φ85xΦ60x685 (H=4000)	Short lifting cylinderΦ85xΦ60x685 (H=	1	
A	256144518003	油缸(M) Φ85xΦ60x748 (H=4300)	Short lifting cylinderΦ85xΦ60x748 (H=	1	
A	256144518004	油缸(M) Φ85xΦ60x772 (H=4500)	Short lifting cylinderΦ85xΦ60x772 (H=	1	
A	256144518005	油缸(M) Φ85xΦ60x805 (H=4700)	Short lifting cylinderΦ85xΦ60x805 (H=	1	
A	256144518006	油缸(M) Φ85xΦ60x822 (H=4800)	Short lifting cylinderΦ85xΦ60x822 (H=	1	
A	256144518007	油缸(M) Φ85xΦ60x879 (H=5000)	Short lifting cylinderΦ85xΦ60x879 (H=	1	
A	256144518008	油缸(M) Φ85xΦ60x979 (H=5400)	Short lifting cylinderΦ85xΦ60x979 (H=	1	
A	256144518009	油缸(M) Φ85xΦ60x995 (H=5500)	Short lifting cylinderΦ85xΦ60x995 (H=	1	
A	256144518010	油缸(M) Φ85xΦ60x1112 (H=6000)	Short lifting cylinderΦ85xΦ60x1112 (H=	1	
A	256144518011	油缸(M) Φ85xΦ60x1229 (H=6500)	Short lifting cylinderΦ85xΦ60x1229 (H=	1	
A	255044510100	油缸(M) Φ75xΦ50x622 (H=3600)	Short lifting cylinder Φ75xΦ50x622 (H=	1	25Q
A	255044510050	油缸(M) Φ75xΦ50x685 (H=4000)	Short lifting cylinder Φ75xΦ50x685 (H=	1	
A	255044510051	油缸(M) Φ75xΦ50x748 (H=4300)	Short lifting cylinder Φ75xΦ50x748 (H=	1	
A	255044510052	油缸(M) Φ75xΦ50x772 (H=4500)	Short lifting cylinder Φ75xΦ50x772 (H=	1	
A	255044510101	油缸(M) Φ75xΦ50x805 (H=4700)	Short lifting cylinder Φ75xΦ50x805 (H=	1	
A	255044510053	油缸(M) Φ75xΦ50x822 (H=4800)	Short lifting cylinder Φ75xΦ50x822 (H=	1	
A	255044510054	油缸(M) Φ75xΦ50x879 (H=5000)	Short lifting cylinder Φ75xΦ50x879 (H=	1	
A	255044510102	油缸(M) Φ75xΦ50x979 (H=5400)	Short lifting cylinder Φ75xΦ50x979 (H=	1	
A	255044510055	油缸(M) Φ75xΦ50x995 (H=5500)	Short lifting cylinder Φ75xΦ50x995 (H=	1	
A	255044510056	油缸(M) Φ75xΦ50x1112 (H=6000)	Short lifting cylinder Φ75xΦ50x1112 (H=	1	
A	255044510103	油缸(M) Φ75xΦ50x1229 (H=6500)	Short lifting cylinder Φ75xΦ50x1229 (H=	1	
B	255098510005	密封件修理包(三级全自由中间缸)	Seal kits (three stage full free	1	包含
C	255044510124	起升链条LH1623-45	Lifting chain LH1623-45	2	H=3600
C	255044510044	起升链条LH1623-47	Lifting chain LH1623-47	2	H=4000
C	255044510045	起升链条LH1623-53	Lifting chain LH1623-53	2	H=4300
C	255044010060	起升链条LH1623-55	Lifting chain LH1623-55	2	H=4500
C	255044510133	起升链条LH1623-59	Lifting chain LH1623-59	2	H=4700/4800
C	255044510134	起升链条LH1623-63	Lifting chain LH1623-63	2	H=5000
C	255044510135	起升链条LH1623-61	Lifting chain LH1623-61	2	H=5400/5500
C	255044510136	起升链条LH1623-71	Lifting chain LH1623-71	2	H=6000

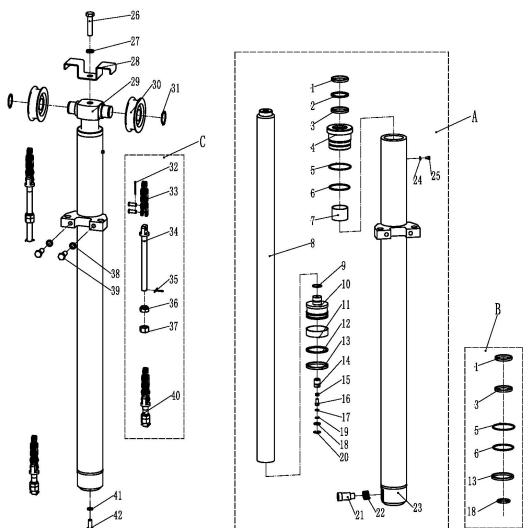

256898501045 短起升油缸(三级全自由门架)/SHORT LIFTING CYLINDER (three stage full free)

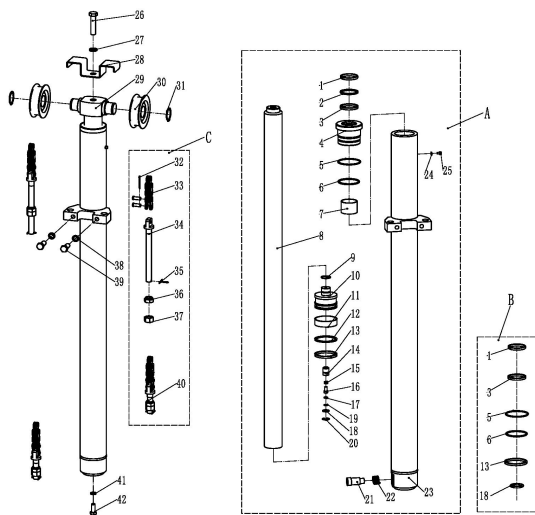

序号/NO	编码/SN	名称	Name	数量/QTY	备注/Remark
C	255044510137	起升链条LH1623-81	Lifting chain LH1623-81	2	H=6500
1	▲	防尘圈	Dust ring 50x58x6.5	1	
2	▲	挡片50×60×3	Catch 50×60×3	1	
3	▲	轴用密封圈	Seal ring 50×60×6	1	
4	▲	导向套	Glide sleeve	1	
5	▲	O型密封圈	O ring 74.4x3.1	1	
6	▲	O型密封圈	O ring 69×3.55	1	
7	▲	钢背轴承5040	Bearing5040	1	
8	▲	活塞杆	Piston rod	1	
9	▲	钢丝挡圈	Circlip	1	
10	▲	活塞总成	Piston assembly	1	
11	▲	支承环75x20x2.5	Support ring 75x20x2.5	1	
12	▲	支承环75x65x3	Support ring 75x65x3	1	
13	▲	孔用密封圈	Seal ring 75x65x6	1	
14	▲	阀套	Valve cover	1	
15	▲	弹簧	Spring	1	
16	▲	阀芯	Valve plug	1	
17	▲	挡片	Catch	1	
18	▲	O型密封圈	O ring D20x2.4	1	
19	▲	孔用弹性挡圈12	Circlip 12	1	
20	▲	孔用弹性挡圈22	Circlip 22	1	
21	▲	滑阀	Slide valve	1	
22	▲	弹簧2.3x15x48.5	Spring2.3x15x48.5	1	
23	▲	缸体	Cylinder	1	
24	▲	垫片	Spacer	1	
25	▲	内六角圆柱头螺钉M5x5	Screw M5x5	1	
26	910100100071	螺栓GB5782-M16x50-8.8	Bolt GB5782-M16x50-8.8	1	
27	910400500010	弹簧垫圈GB93-16	Washer GB93-16	1	
28	255043520020	挡链板	Block chain plate	1	
29	255043520006	缸头	Cylinder head	1	
30	940200500001	链轮轴承780708K-φ110xφ40x27	Chain wheel bearing 780708K-φ110xφ40x27	2	

256898501046 起升油缸(三级全自由门架)/LIFTING CYLINDER (three stage full free)

序号/NO	编码/SN	名称	Name	数量/QTY	备注/Remark
1	910100300023	螺栓GB5783-M8x25-8.8	Bolt GB5783-M8x25-8.8	4	
2	910400500007	弹簧垫圈GB93-10	Washer GB93-10	4	
3	910400100007	平垫圈GB97.1-10-200HV	Washer GB97.1-10-200HV	4	
4	255044520099	橡胶垫	Rubber pad	2	
5	255044520097	支撑块	Support block	2	
6	255044520098	弯板	Blendboard	2	
7	256144516001	油缸(L)(H=3600)	Cylinder (L)Φ56xΦ45x1174(H=3600)	1	28Q/30Q/35Q
	256144516002	油缸(L)(H=4000)	Cylinder (L)Φ56xΦ45x1312(H=4000)	1	
	256144516003	油缸(L)(H=4300)	Cylinder (L)Φ56xΦ45x1424(H=4300)	1	
	256144516004	油缸(L)(H=4500)	Cylinder (L)Φ56xΦ45x1474(H=4500)	1	
	256144516005	油缸(L)(H=4700)	Cylinder (L)Φ56xΦ45x1539(H=4700)	1	
	256144516006	油缸(L)(H=4800)	Cylinder (L)Φ56xΦ45x1574(H=4800)	1	
	256144516007	油缸(L)(H=5000)	Cylinder (L)Φ56xΦ45x1617(H=5000)	1	
	256144516008	油缸(L)(H=5400)	Cylinder (L)Φ56xΦ45x1717(H=5400)	1	
	256144516009	油缸(L)(H=5500)	Cylinder (L)Φ56xΦ45x1751(H=5500)	1	
	256144516010	油缸(L)(H=6000)	Cylinder (L)Φ56xΦ45x1884(H=6000)	1	
	256144516011	油缸(L)(H=6500)	Cylinder (L)Φ56xΦ45x2017(H=6000)	1	
7	255044510104	油缸(L)Φ50xΦ40x1174	Cylinder (L)Φ50xΦ40x1174(H=3600)	1	25Q
	255044510004	油缸(L)Φ50xΦ40x1312	Cylinder (L)Φ50xΦ40x1312(H=4000)	1	
	255044510005	油缸(L)Φ50xΦ40x1424	Cylinder (L)Φ50xΦ40x1424(H=4300)	1	
	255044510006	油缸(L)Φ50xΦ40x1474	Cylinder (L)Φ50xΦ40x1474(H=4500)	1	
	255044510105	油缸(L)Φ50xΦ40x1539	Cylinder (L)Φ50xΦ40x1539(H=4700)	1	
	255044510007	油缸(L)Φ50xΦ40x1574	Cylinder (L)Φ50xΦ40x1574(H=4800)	1	
	255044510008	油缸(L)Φ50xΦ40x1617	Cylinder (L)Φ50xΦ40x1617(H=5000)	1	
	255044510106	油缸(L)Φ50xΦ40x1717	Cylinder (L)Φ50xΦ40x1717(H=5400)	1	
	255044510009	油缸(L)Φ50xΦ40x1751	Cylinder (L)Φ50xΦ40x1751(H=5500)	1	
	255044510010	油缸(L)Φ50xΦ40x1884	Cylinder (L)Φ50xΦ40x1884(H=6000)	1	
255044510107	油缸(L)Φ50xΦ40x2017	Cylinder (L)Φ50xΦ40x2017(H=6500)	1		
8	910300100007	螺钉M10x35-8.8	Screw M10x35-8.8	2	
9	941100100003	螺母GB6170-M10-10	Nut GB6170-M10-10	2	
10	910400100008	平垫圈GB97.1-12-200HV	Washer GB97.1-12-200HV	2	

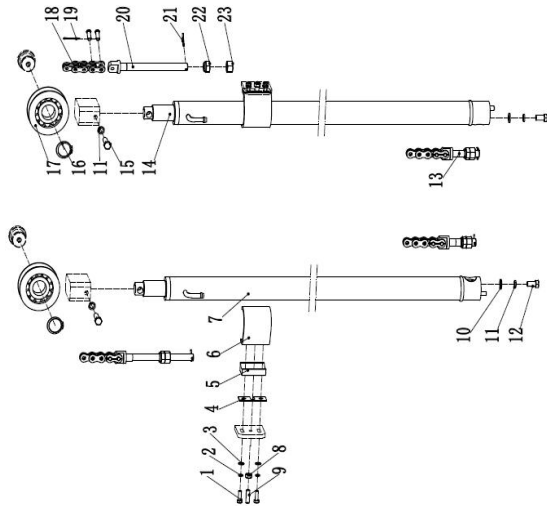
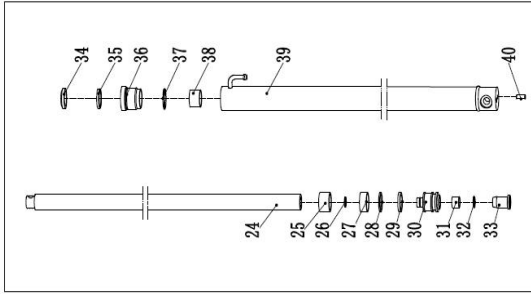

256898501046 起升油缸(三级全自由门架)/LIFTING CYLINDER (three stage full free)

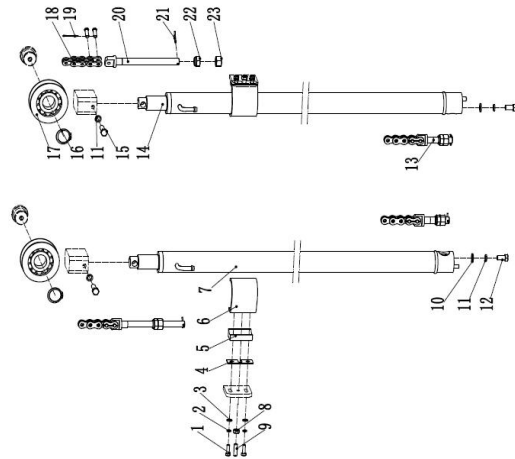
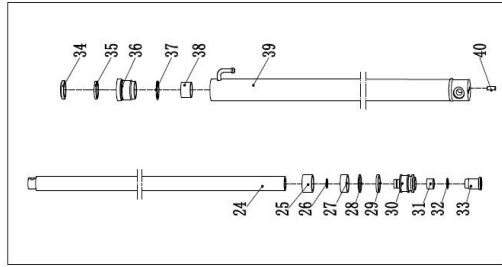

序号/NO	编码/SN	名称	Name	数量/QTY	备注/Remark
11	910400500008	弹簧垫圈GB93-12	Washer GB93-12	4	
12	910100400009	螺栓GB5786-M12x1.25x25-8.8	Bolt GB5786-M12x1.25x25-8.8	2	
13	255044020156	短端接头	Joint	2	28Q/30Q/35Q
14	256144517001	油缸 (R) (H=3600)	CyRinder (R)Φ56xΦ45x1174(H=3600)	1	
	256144517002	油缸 (R) (H=4000)	CyRinder (R)Φ56xΦ45x1312(H=4000)	1	
	256144517003	油缸 (R) (H=4300)	CyRinder (R)Φ56xΦ45x1424(H=4300)	1	
	256144517004	油缸 (R) (H=4500)	CyRinder (R)Φ56xΦ45x1474(H=4500)	1	
	256144517005	油缸 (R) (H=4700)	CyRinder (R)Φ56xΦ45x1539(H=4700)	1	
	256144517006	油缸 (R) (H=4800)	CyRinder (R)Φ56xΦ45x1574(H=4800)	1	
	256144517007	油缸 (R) (H=5000)	CyRinder (R)Φ56xΦ45x1617(H=5000)	1	
	256144517008	油缸 (R) (H=5400)	CyRinder (R)Φ56xΦ45x1717(H=5400)	1	
	256144517009	油缸 (R) (H=5500)	CyRinder (R)Φ56xΦ45x1751(H=5500)	1	
	256144517010	油缸 (R) (H=6000)	CyRinder (R)Φ56xΦ46x1884(H=6000)	1	
	256144517011	油缸 (R) (H=6500)	CyRinder (R)Φ56xΦ45x2017H=6000)	1	25Q
14	255044510108	油缸 (R) (H=3600)	CyRinder (R)Φ50xΦ40x1174(H=3600)	1	
	255044510011	油缸 (R) (H=4000)	CyRinder (R)Φ50xΦ40x1312(H=4000)	1	
	255044510012	油缸 (R) (H=4300)	CyRinder (R)Φ50xΦ40x1424(H=4300)	1	
	255044510013	油缸 (R) (H=4500)	CyRinder (R)Φ50xΦ40x1474(H=4500)	1	
	255044510109	油缸 (R) (H=4700)	CyRinder (R)Φ50xΦ40x1539H=4700)	1	
	255044510014	油缸 (R) (H=4800)	CyRinder (R)Φ50xΦ40x1574(H=4800)	1	
	255044510015	油缸 (R) (H=5000)	CyRinder (R)Φ50xΦ40x1617(H=5000)	1	
	255044510110	油缸 (R) (H=5400)	CyRinder (R) Φ 50x Φ 40x1717 (H=5400)	1	
	255044510016	油缸 (R) (H=5500)	CyRinder (R) Φ 50x Φ 40x1751 (H=5500)	1	
	255044510017	油缸 (R) (H=6000)	CyRinder (R) Φ 50x Φ 40x1884 (H=6000)	1	
255044510111	油缸 (R) (H=6500)	CyRinder (R) Φ 50x Φ 40x2017H=6000)	1		
15	910100300053	螺栓GB5783-M12x45-8.8	Bolt GB5783-M12x45-8.8	2	
16	910401300020	轴用弹性挡圈GB894.1-40	Circlip GB894.1-40	2	
17	940200500005	链轮轴承780708K-φ110xφ40x27	Chain wheel bearing 780708K-φ110x	2	
18	910900400014	LH1623板式链	LH1623chain	2	
19	910600600022	开口销2.5x40	Split pin 2.5x40	2	
20	255044020157	链条螺栓M18x1.5x217	Joint	2	

256898501046 起升油缸(三级全自由门架)/LIFTING CYLINDER (three stage full free)

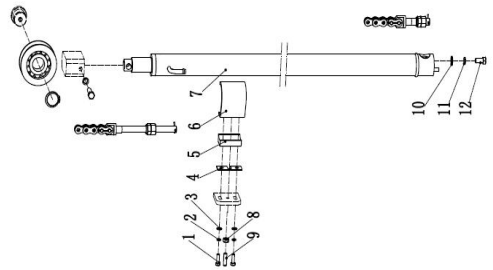
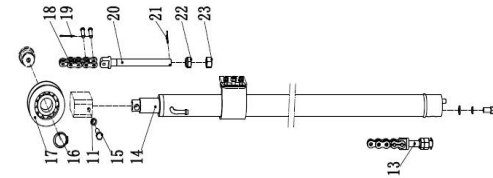
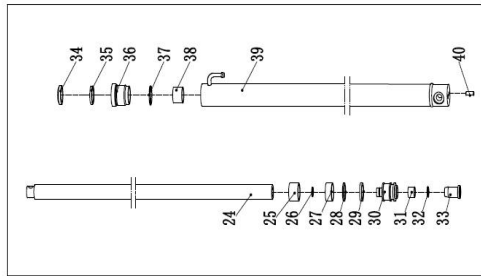

序号/NO	编码/SN	名称	Name	数量/QTY	备注/Remark
21	910600600030	开口销GB91-3. 2x30	Split pin 3.2x30	2	
22	255044020158	球面螺母M18x1. 5	Nut M18x1.5	2	
23	910300400007	螺母GB6173-M18x1. 5-05	Nut M18x1.5-05	2	
24	▲	活塞杆	Piston rod	1	
25	▲	调整套40. 5x49xL2	Adjusting bushing 40.5x49xL2	1	
26	▲	钢丝挡圈 φ 24x2	Circlip φ24x2	1	
27	▲	支承56x20x2. 5	Bearing 56x20x2.5	1	
28	▲	挡片56x44x3	Catch 56x45x3	1	
29	▲	孔用密封圈	Seal ring 56x45x6	1	
30	▲	活塞	Piston	1	
31	▲	铜套	Copper bushing	1	
32	▲	钢丝挡圈 φ 26. 5x2	Circlip φ26.5x2	1	
33	▲	缓冲环	Buffer ring	1	
34	▲	防尘圈	Dust ring DKB45x58x7/10	1	
35	▲	轴用密封圈	Seal ring 40x50x6	1	
36	▲	导向套	Guide bushing	1	
37	▲	O型密封圈	O seal ring 49.7x2.4	1	
38	▲	钢背轴承4030	Bearing 4030	1	
39	▲	缸体	Cylinder	1	
40	▲	圆柱销D10x26	Dowel pin D10x26	1	
41	256198510003	30-35N密封件修理包(三级全自由起升)	Seal kits(three stage full free lifting cyl	2	包含/Inc
A	256844014002	起升链条LH1623-65	Lifting chainLH1623-65	2	H=3600
	255044510046	起升链条LH1623-69	Lifting chainLH1623-69	2	H=4000
	255044510138	起升链条LH1623-73	Lifting chainLH1623-73	2	H=4350
	255044510047	起升链条LH1623-75	Lifting chainLH1623-75	2	H=4500
	255043510139	起升链条LH1623-79	Lifting chainLH1623-79	2	H=4700/4800
	255044510140	起升链条LH1623-85	Lifting chainLH1623-85	2	H=5000
	255044510048	起升链条LH1623-95	Lifting chainLH1623-95	2	H=5400/5500
	255044510049	起升链条LH1623-103	Lifting chainLH1623-103	2	H=6000
	255044510125	起升链条LH1623-113	Lifting chainLH1623-113	2	H=6500

256898501047 起升管路(三级全自由门架)/LIFTING CYLINDER (three stage full free)

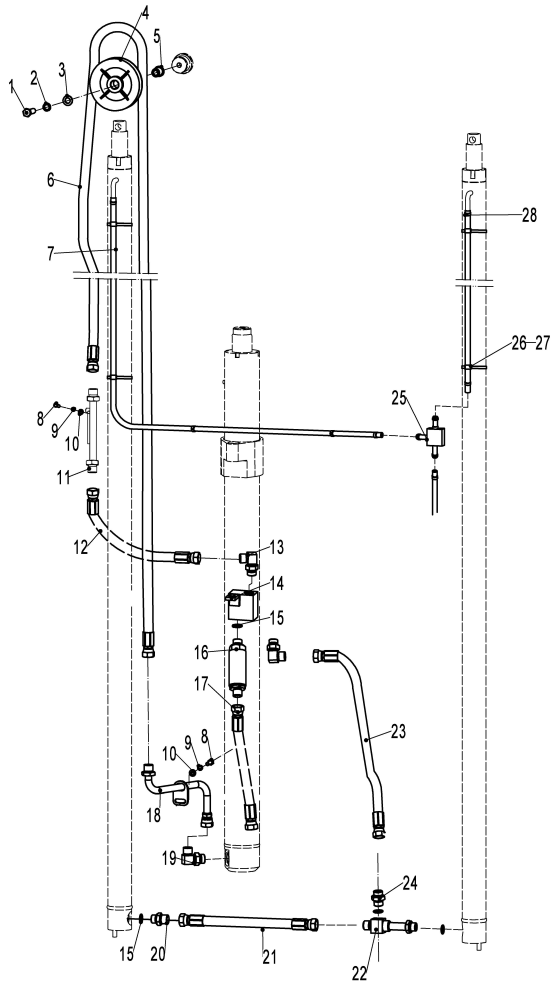

序号/NO	编码/SN	名称	Name	数量/QTY	备注/Remark
1	910100100048	螺栓GB5782-M12x50-8.8	Bolt GB5782-M12x50-8.8	1	
2	910400500008	弹簧垫圈GB93-12	Spring washer gb93-12	1	
3	910400100008	平垫圈GB97.1-12-200HV	Flat washer GB97.1-12-200HV	1	
4	255044520096	滑轮Φ120x36(单槽)	Pulley Φ120x36 (single slot)	1	
5	255044520081	衬套(带肩)Φ20xΦ13x28	Bushings (shoulder)Φ20xΦ13x28	1	
6	255044520084	液压管总成(直)15-L1910-2SC-60°	Hydraulic hose assembly 15-L1910-2S	1	H=3600
6	255044520071	液压管总成(直)15-L2180-2SC-60°	Hydraulic hose assembly 15-L2180-2S	1	H=4000
6	255044520072	液压管总成(直)15-L2430-2SC-60°	Hydraulic hose assembly 15-L2430-2S	1	H=4350
6	255044520073	液压管总成(直)15-L2530-2SC-60°	Hydraulic hose assembly 15-L2530-2S	1	H=4500
6	255044520074	液压管总成(直)15-L2730-2SC-60°	Hydraulic hose assembly 15-L2730-2S	1	H=4700/4800
6	255044520075	液压管总成(直)15-L3015-2SC-60°	Hydraulic hose assembly 15-L3015-2S	1	H=5000
6	255044520076	液压管总成(直)15-L3480-2SC-60°	Hydraulic hose assembly 15-L3480-2S	1	H=5400/5500
6	255044520077	液压管总成(直)15-L3950-2SC-60°	Hydraulic hose assembly 15-L3950-2S	1	H=6000
6	255044520124	液压管总成(直)15-L4410-2SC-60°	Hydraulic hose assembly 15-L4410-2S	1	H=6500
7	▲	PE软管Φ10xΦ13	PE Supple pipeΦ10xΦ13	3	
8	910100300022	螺栓GB5783-M8x20-8.8	Bolt GB5783-M8x20-8.8	3	
9	910400500006	弹簧垫圈GB93-8	Spring washer GB93-8	5	
10	910400100006	平垫圈GB97.1-8-200HV	Flat washer GB97.1-8-200HV	5	
11	255044510020	液压钢管焊合1	Hydraulic pipe welding 1	1	
12	255044520083	液压管总成(直)15-L530-2SC-60°	Hydraulic hose assembly 15-L530-2S	1	
13	255044020151	接头(锁定弯)12-2xM22x1.5-60°	Connector (lock bend) 12-2xM22x1.5-	1	
14	252144519002	三通焊合(20Q)	Tee welded (20Q)	1	
15	910800100040	O形圈-外24x2.4	O - inner 24x2.4	4	
16	950700300002	限速阀XSF-F16L-48	The speed limit valve XSF-F16L-48	1	
17	252144529003	液压管总成(直)15-L800-2SC-60°	Hydraulic hose assembly 15-L800-2S	1	
18	255044510021	液压钢管焊合2	Hydraulic pipe welding 2	1	
19	255043520022	接头(锁定弯)12-M27x2-M22x1.5	Connector (lock bend) 12-M27x2-M22	1	
20	256898520001	防爆阀	explosion-proof valve	1	
21	255044520067	液压管总成(直)15-L360-2SC-60°	Hydraulic hose assembly 15-L360-2S	1	
22	255044010040	接头(三通)	Connector (tee)	1	
23	254144520048	液压管总成(90°)15-L800-2SC-60°	Hydraulic hose assembly (90°)15-L	1	

256898501048 侧移器及管路安装(三级全自由)/Side shifter and pipeline installation(three stage full free)

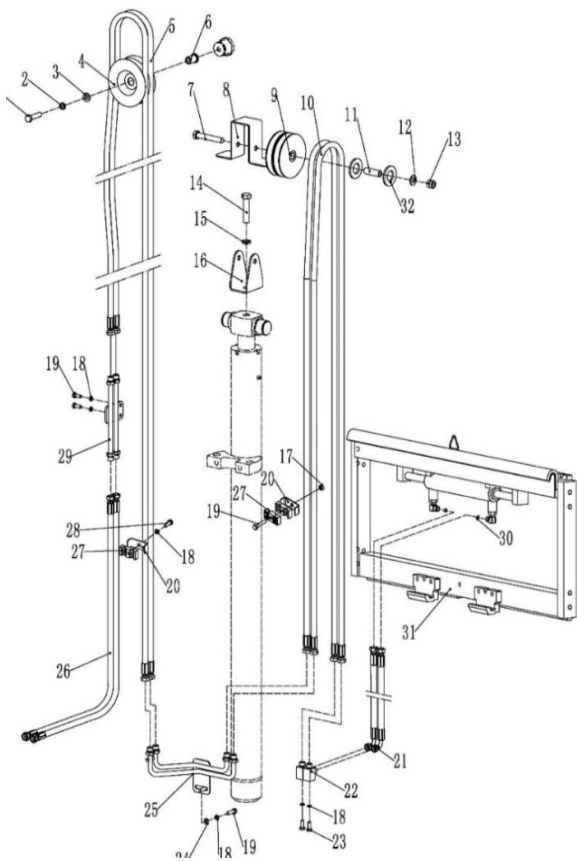

序号/NO	编码/SN	名称	Name	数量/QTY	备注/Remark
1	910100100048	螺栓GB5782-M12x50-8.8	BoltGB5782-M12x50-8.8	1	
2	910400500008	弹簧垫圈GB93-12	Washer GB93-12	1	
3	910400100008	平垫圈GB97.1-12-200HV	Washer GB97.1-12-200HV	2	
4	255030520020	滑轮Φ120x42(双槽)	Pulley Φ120 x42 (dual slot)	1	
5	255023520036	液压管总成(直)10-L1800-1SC-60°	Hydraulic hose assembly 10-L1800-1SC-60°	2	H=3600
5	255030520001	液压管总成(直)10-L2060-1SC-60°	Hydraulic hose assembly 10-L2060-1SC-60°	2	H=4000
5	255030520002	液压管总成(直)10-L2310-1SC-60°	Hydraulic hose assembly 10-L2310-1SC-60°	2	H=4300
5	255030520003	液压管总成(直)10-L2410-1SC-60°	Hydraulic hose assembly 10-L2410-1SC-60°	2	H=4500
5	255030520004	液压管总成(直)10-L2610-1SC-60°	Hydraulic hose assembly 10-L2610-1SC-60°	2	H=4800/4700
5	255030520005	液压管总成(直)10-L2900-1SC-60°	Hydraulic hose assembly 10-L2900-1SC-60°	2	H=5000
5	255030520006	液压管总成(直)10-L3370-1SC-60°	Hydraulic hose assembly 10-L3370-1SC-60°	2	H=5500/5400
5	255030520007	液压管总成(直)10-L3840-1SC-60°	Hydraulic hose assembly 10-L3840-1SC-60°	2	H=6000
5	263030520008	液压管总成(直)10-L4330-1SC-60°	Hydraulic hose assembly 10-L4330-1SC-60°	2	H=6500
6	255030520023	衬套1	Bushing	1	
7	910100100058	螺栓GB5782-M12x100-8.8	Bolt GB5782-M12x100-8.8	1	
8	255028520043	挡板	Chain plate	1	
9	255030520021	滑轮Φ110x27(单槽)	Pulley φ110x27	2	
10	255023520036	液压管总成(直)10-L1800-1SC-60°	Hydraulic hose assembly 10-L1800-1SC-60°	2	H=3600
10	255028520016	液压管总成(直)10-L1930-1SC-60°	Hydraulic hose assembly 10-L1930-1SC-60°	2	H=4000
10	275323521007	液压管总成(直)10-L2040-1SC-60°	Hydraulic hose assembly 10-L2040-1SC-60°	2	H=4350
10	255030520711	液压管总成(直)10-L2090-1SC-60°	Hydraulic hose assembly 10-L2090-1SC-60°	2	H=4500
10	263030520015	液压管总成(直)10-L2160-1SC-60°	Hydraulic hose assembly 10-L2160-1SC-60°	2	H=4800/4700
10	255028520045	液压管总成(直)10-L2300-1SC-60°	Hydraulic hose assembly 10-L2300-1SC-60°	2	H=5000
10	281229020031	液压管总成(直)10-L2500-1SC-60°	Hydraulic hose assembly 10-L2500-1SC-60°	2	H=5500/5400
10	254131020006	液压管总成(直)10-L2750-1SC-60°	Hydraulic hose assembly 10-L2750-1SC-60°	2	H=6000
10	281229020023	液压管总成(直)10-L2975-1SC-60°	Hydraulic hose assembly 10-L2975-1SC-60°	2	H=6500
11	255030520022	衬套Φ22xΦ13x56	Bush Φ22xΦ13x56	1	
12	910400100008	平垫圈GB97.1-12-200HV	Washer GB97.1-12-200HV	2	
13	910300500006	螺母GB889.1-M12-10	Nut GB889.1-M12-10	1	
14	910100100072	螺栓GB5782-M16x60-8.8	Bolt GB5782-M16x60-8.8	1	
15	910400100010	平垫圈GB97.1-16-200HV	Washer GB97.1-16-200HV	1	

256898501049 双附加管路(三级全自由)/DOUBLE ADDITIONAL TUBE(three stage full free)

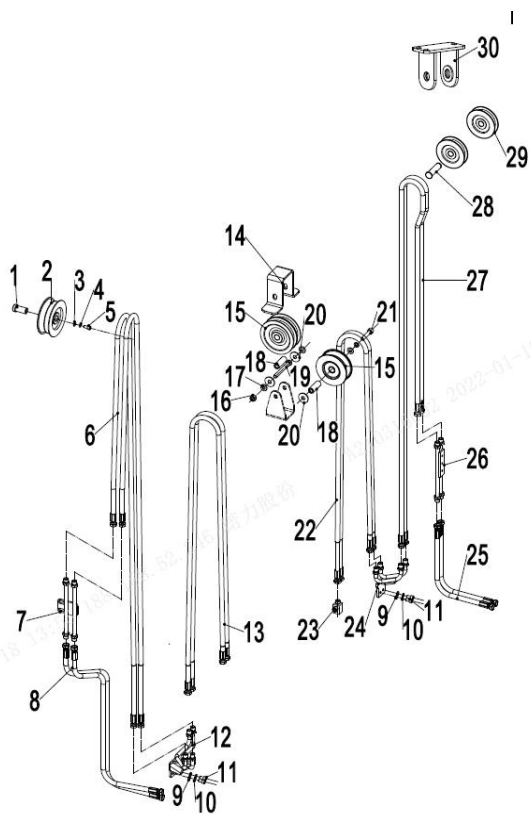

序号/NO	编码/SN	名称	Name	数量/QTY	备注/Remark
1	254130520016	衬套Φ20xΦ13x43	Bush Φ20xΦ13x43	1	
2	255030520020	滑轮Φ120x42(双槽)	Pulley Φ120x42	1	
3	910400500008	弹簧垫圈GB93-12	WasherGB93-12	1	
4	910400100008	平垫圈GB97.1-12-200HV	Washer GB97.1-12-200HV	1	
5	910100100048	螺栓GB5782-M12x50-8.8	Bolt GB5782-M12x50-8.8	1	
6	255023520036	液压管总成(直)10-L1800-1SC-60°	Hydraulic hose assembly 10-L1800-1S	2	H=3600
6	255030520001	液压管总成(直)10-L2060-1SC-60°	Hydraulic hose assembly 10-L2060-1S	2	H=4000
6	255030520002	液压管总成(直)10-L2310-1CS-60°	Hydraulic hose assembly 10-L2310-1S	2	H=4300
6	255030520003	液压管总成(直)10-L2410-1CS-60°	Hydraulic hose assembly 10-L2410-1S	2	H=4500
6	255030520004	液压管总成(直)10-L2610-1CS-60°	Hydraulic hose assembly 10-L2610-1S	2	H=4800/4700
6	255030520005	液压管总成(直)10-L2900-1CS-60°	Hydraulic hose assembly 10-L2900-1S	2	H=5000
6	255030520006	液压管总成(直)10-L3370-1CS-60°	Hydraulic hose assembly 10-L3370-1S	2	H=5500/5400
6	255030520007	液压管总成(直)10-L3840-1CS-60°	Hydraulic hose assembly 10-L3840-1S	2	H=6000
6	263030520008	液压管总成(直)10-L4330-1CS-60°	Hydraulic hose assembly 10-L4330-1S	2	H=6500
7	255030520018	液压钢管焊合1	Hydraulic steel pipe welding 1	1	
8	255030520017	液压管总成(直)10-L1450-1SC-60°	Hydraulic hose assembly 10-L1450-1S	2	
9	910400100006	平垫圈GB97.1-8-200HV	Washer GB97.1-8-200HV	5	
10	910400500006	弹簧垫圈GB93-8	WasherGB93-8	8	
11	910100300022	螺栓GB5783-M8x20-8.8	Bolt GB5783-M8x20-8.8	7	
12	255030520019	液压钢管焊合2	Hydraulic steel pipe welding 2	1	
13	255023520036	液压管总成(直)10-L1800-1SC-60°	Hydraulic hose assembly 10-L1800-1S	2	H=3600
13	255028520016	液压管总成(直)10-L1930-1SC-60°	Hydraulic hose assembly 10-L1930-1S	2	H=4000
13	275323521007	液压管总成(直)10-L2040-1SC-60°	Hydraulic hose assembly 10-L2040-1S	2	H=4350
13	255030520711	液压管总成(直)10-L2090-1SC-60°	Hydraulic hose assembly 10-L2090-1S	2	H=4500
13	263030520015	液压管总成(直)10-L2160-1SC-60°	Hydraulic hose assembly 10-L2160-1S	2	H=4800/4700
13	255028520045	液压管总成(直)10-L2300-1SC-60°	Hydraulic hose assembly 10-L2300-1S	2	H=5000
13	281229020031	液压管总成(直)10-L2500-1SC-60°	Hydraulic hose assembly 10-L2500-1S	2	H=5500/5400
13	254131020006	液压管总成(直)10-L2750-1SC-60°	Hydraulic hose assembly 10-L2750-1S	2	H=6000
13	281229020023	液压管总成(直)10-L2975-1SC-60°	Hydraulic hose assembly 10-L2975-1S	2	H=6500
14	255028520043	挡板	Chain plate	1	
15	255030520021	滑轮Φ110x27(单槽)	Pulley Φ110x27	4	

256898501049 双附加管路(三级全自由)/DOUBLE ADDITIONAL TUBE(three stage full free)

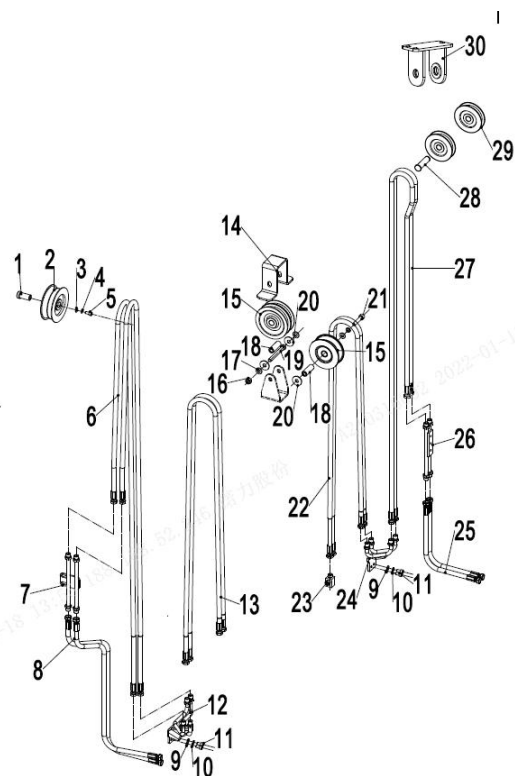

序号/NO	编码/SN	名称	Name	数量/QTY	备注/Remark
16	910300500006	螺母GB889.1-M12-10	Nut GB889.1-M12-10	1	
17	910400100008	平垫圈GB97.1-12-200HV	Washer GB97.1-12-200HV	1	
18	255030520022	衬套Φ20xΦ13x56	BushΦ20xΦ13x56	1	
19	910100100058	螺栓GB5782-M12x100-8.8	Bolt GB5782-M12x100-8.8	1	
20	910400200005	大垫圈GB96.1-12-200HV	Washer GB96.1-12-200HV	2	
21	910100100056	螺栓GB5782-M12x90-8.8	Bolt GB5782-M12x90-8.8	1	
22	275230529021	液压管总成(直)10-L1600-1SC-60°	Hydraulic hose assembly 10-L1600-1SC-60°	2	H=3600
22	255030520024	液压管总成(直)10-L1720-1SC-60°	Hydraulic hose assembly 10-L1720-1SC-60°	2	H=4000
22	254130520005	液压管总成(直)10-L1890-1SC-60°	Hydraulic hose assembly 10-L1890-1SC-60°	2	H=4350/4500
22	255031020705	液压管总成(直)10-L1980-1SC-60°	Hydraulic hose assembly 10-L1980-1SC-60°	2	H=4800/4700
22	255028520044	液压管总成(直)10-L2150-1SC-60°	Hydraulic hose assembly 10-L2150-1SC-60°	2	H=5000
22	254128520031	液压管总成(直)10-L2350-1SC-60°	Hydraulic hose assembly 10-L2350-1SC-60°	2	H=5400/5500
22	255031020016	液压管总成(直)10-L2550-1SC-60°	Hydraulic hose assembly 10-L2550-1SC-60°	2	J=6000
22	255031020703	液压管总成(直)10-L2780-1SC-60°	Hydraulic hose assembly 10-L2780-1SC-60°	2	H=6500
23	255029020024	接头(锁定弯)8-2xM16x1.5-60°	Joint 8-2xM16x1.5-60°	4	
24	255031020006	液压钢管焊合	Hydraulic steel pipe welding	1	
25	255031020008	液压管总成(135°)10-L1000-1SC-60°	Hydraulic hose assembly (135°)10-L1000-1SC-60°	2	
26	255028510022	过渡钢管	Excessive pipe welding	1	
27	254130520007	液压管总成(直)10-L2140-1SC-60°	Hydraulic hose assembly 10-L2140-1SC-60°	2	H=3600
27	255030520003	液压管总成(直)10-L2410-1SC-60°	Hydraulic hose assembly 10-L2410-1SC-60°	2	H=4000
27	254128520052	液压管总成(直)10-L2650-1SC-60°	Hydraulic hose assembly 10-L2650-1SC-60°	2	H=4350
27	254131020006	液压管总成(直)10-L2750-1SC-60°	Hydraulic hose assembly 10-L2750-1SC-60°	2	H=4500
27	254131020007	液压管总成(直)10-L2950-1SC-60°	Hydraulic hose assembly 10-L2950-1SC-60°	2	H=4700/4800
27	254128520039	液压管总成(直)10-L3250-1SC-60°	Hydraulic hose assembly 10-L3250-1SC-60°	2	H=5000
27	275344529012	液压管总成(直)10-L3350-1SC-60°	Hydraulic hose assembly 10-L3350-1SC-60°	2	H=5400/5500
27	255031020017	液压管总成(直)10-L3720-1SC-60°	Hydraulic hose assembly 10-L3720-1SC-60°	2	H=6000
27	252127521001	液压管总成(直)10-L4150-1SC-60°	Hydraulic hose assembly 10-L4150-1SC-60°	1	H=6500
28	255031020004	带耳轴Φ20x70	Axle Φ20x70	1	
29	255031020007	滑轮Φ90x22(单槽)	Pulley Φ90x22	2	
30	255031010001	滑轮支架焊合1	Pulley support welded 1	1	H>5400
30	255031010002	滑轮支架焊合2	Pulley support welded 2	1	H<=5400

256898501050 门架(两级全自由门架)/MAST(two stage full free)

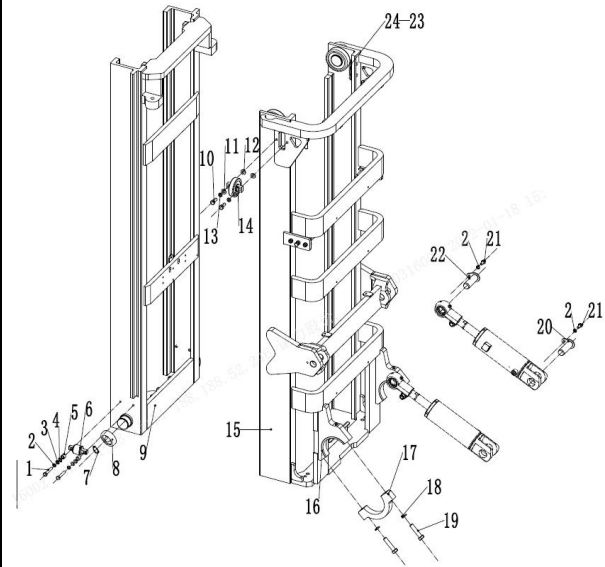

序号/NO	编码/SN	名称	Name	数量/QTY	备注/Remark
1	910100300039	螺栓GB5783-M10x40-8.8	Bolt GB5783-M10x40-8.8	4	
2	910400500007	弹簧垫圈GB93-10	Washer GB93-10	8	
3	910400100007	平垫圈GB97.1-10-200HV	Washer GB97.1-10-200HV	4	
4	255038020009	调整垫	Adjustable pad	8	
5	255038020008	调整套	Adjusting sleeve	4	
6	940200200005	侧滚轮Φ42-CD=68	Side rollerΦ42 - CD = 68	2	
7	910401300024	轴用弹性挡圈	Elastic retaining ring for shaft	4	
8	940200100024	主滚轮Φ111xΦ55x32	RollerΦ111xΦ55x32	4	
8	940200100025	主滚轮Φ111.5xΦ55x32	RollerΦ111.5xΦ55x32	4	
9	256843512001	内门架焊合 2000	Inner mast(2000)	1	28Q/30Q/35Q
9	256843512002	内门架焊合 2500	Inner mast 2500	1	28Q/30Q/35Q
9	256843512003	内门架焊合 3000	Inner mast 3000	1	28Q/30Q/35Q
9	256843512004	内门架焊合 3300	Inner mast 3300	1	28Q/30Q/35Q
9	256843512005	内门架焊合 3500	Inner mast 3500	1	28Q/30Q/35Q
9	256843512006	内门架焊合 3600	Inner mast 3600	1	28Q/30Q/35Q
9	256843512007	内门架焊合 3700	Inner mast 3700	1	28Q/30Q/35Q
9	256843512008	内门架焊合 4000	Inner mast 4000	1	28Q/30Q/35Q
9	256843512009	内门架焊合 4300	Inner mast 4300	1	28Q/30Q/35Q
9	256843512010	内门架焊合 4500	Inner mast 4500	1	28Q/30Q/35Q
9	256843512011	内门架焊合 5000	Inner mast 5000	1	28Q/30Q/35Q
9	256843512012	内门架焊合 5500	Inner mast 5500	1	28Q/30Q/35Q
9	256843512013	内门架焊合 6000	Inner mast 6000	1	28Q/30Q/35Q
9	255043510027	内门架焊合 2000	Inner mast (2000)	1	25Q
9	255043510028	内门架焊合 2500	Inner mast 2500	1	25Q
9	255043510029	内门架焊合 3000	Inner mast 3000	1	25Q
9	255043510030	内门架焊合 3300	Inner mast 3300	1	25Q
9	255043510031	内门架焊合 3500	Inner mast 3500	1	25Q
9	255043510032	内门架焊合 3600	Inner mast 3600	1	25Q
9	255043510033	内门架焊合 3700	Inner mast 3700	1	25Q
9	255043510034	内门架焊合 4000	Inner mast 4000	1	25Q
9	255043510035	内门架焊合 4300	Inner mast 4300	1	25Q

256898501050 门架(两级全自由门架)/MAST(two stage full free)

序号/NO	编码/SN	名称	Name	数量/QTY	备注/Remark
9	255043510036	内门架焊合 4500	Inner mast 4500	1	25Q
9	255043510037	内门架焊合 5000	Inner mast 5000	1	25Q
9	255043510038	内门架焊合 5500	Inner mast 5500	1	25Q
9	255043510039	内门架焊合 6000	Inner mast 6000	1	25Q
10	910100300050	螺栓GB5783-M12x30-8.8	Bolt GB5783-M12x30-8.8	4	
11	910400100008	平垫圈GB97.1-12-200HV	Washer GB97.1-12-200HV	4	
12	256544002001	垫圈Φ20xΦ13集合图	Washer Φ20xΦ13	4	
13	910400500008	弹簧垫圈GB93-12	Washer GB93-12	4	
14	940200200002	侧滚轮Φ87-CD=55	Side roller Φ87-CD=55	2	
15	256844011001	外门架焊合 2000	Outer mast 2000	1	30Q/35Q
15	256844011002	外门架焊合 2500	Outer mast 2500	1	30Q/35Q
15	256844011003	外门架焊合 3000	Outer mast 3000	1	30Q/35Q
15	256844011004	外门架焊合 3300	Outer mast 3300	1	30Q/35Q
15	256844011005	外门架焊合 3500	Outer mast 3500	1	30Q/35Q
15	256844011006	外门架焊合 3600	Outer mast 3600	1	30Q/35Q
15	256844011007	外门架焊合 3700	Outer mast 3700	1	30Q/35Q
15	256844011008	外门架焊合 4000	Outer mast 4000	1	30Q/35Q
15	256844011009	外门架焊合 4300	Outer mast 4300	1	30Q/35Q
15	256844011010	外门架焊合 4500	Outer mast 4500	1	30Q/35Q
15	256844011011	外门架焊合 5000	Outer mast 5000	1	30Q/35Q
15	256844011012	外门架焊合 5500	Outer mast 5500	1	30Q/35Q
15	256844011013	外门架焊合 6000	Outer mast 6000	1	30Q/35Q
15	256743511001	外门架焊合 2000	Outer mast 2000	1	25Q/28Q
15	256743511002	外门架焊合 2500	Outer mast 2500	1	25Q/28Q
15	256743511003	外门架焊合 3000	Outer mast 3000	1	25Q/28Q
15	256743511004	外门架焊合 3300	Outer mast 3300	1	25Q/28Q
15	256743511005	外门架焊合 3500	Outer mast 3500	1	25Q/28Q
15	256743511006	外门架焊合 3600	Outer mast 3600	1	25Q/28Q
15	256743511007	外门架焊合 3700	Outer mast 3700	1	25Q/28Q
15	256743511008	外门架焊合 4000	Outer mast 4000	1	25Q/28Q
15	256743511009	外门架焊合 4300	Outer mast 4300	1	25Q/28Q

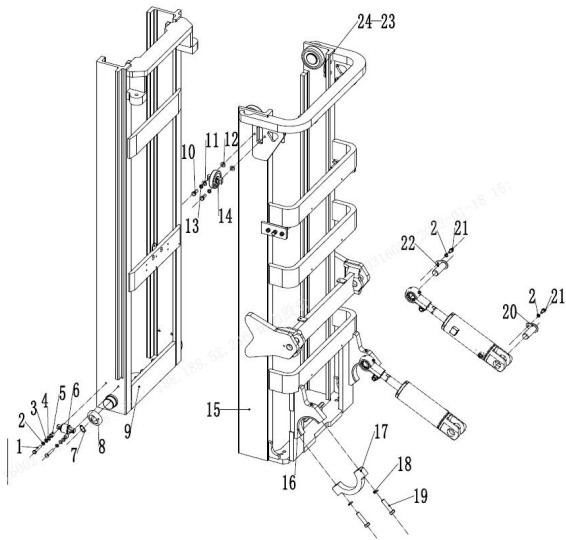

256898501050 门架(两级全自由门架)/MAST(two stage full free)

序号/NO	编码/SN	名称	Name	数量/QTY	备注/Remark
15	256743511010	外门架焊合 4500	Outer mast 4500	1	25Q/28Q
15	256743511011	外门架焊合 5000	Outer mast 5000	1	25Q/28Q
15	256743511012	外门架焊合5500	Outer mast 5500	1	25Q/28Q
15	256743511013	外门架焊合 6000	Outer mast 6000	1	25Q/28Q
16	254144020063	轴瓦	Bearing bush	2	
17	256844021014	支座盖	Bearing cover	2	
18	910400500010	弹簧垫圈GB93-16	Washer GB93-16	7	
19	910100200016	螺栓GB5785-M16x1.5x70-8.8	Bolt GB5785-M16x1.5x70-8.8	4	
20	255044010057	带耳轴 Φ30x82	Axle Φ30x82	2	
21	910100300035	螺栓GB5783-M10x20-8.8	Bolt GB5783-M10x20-8.8	4	
22	256844501001	带耳轴 Φ30x94	Axle Φ30x94	2	
23	255044020132	调整垫片t=0.8	Adjusting pad t=0.8	2	
23	255044020133	调整垫片t=0.5	Adjusting pad t=0.5	2	
23	255044020134	调整垫片t=0.2	Adjusting pad t=0.2	2	
24	255044020131	垫板	Base plate	2	

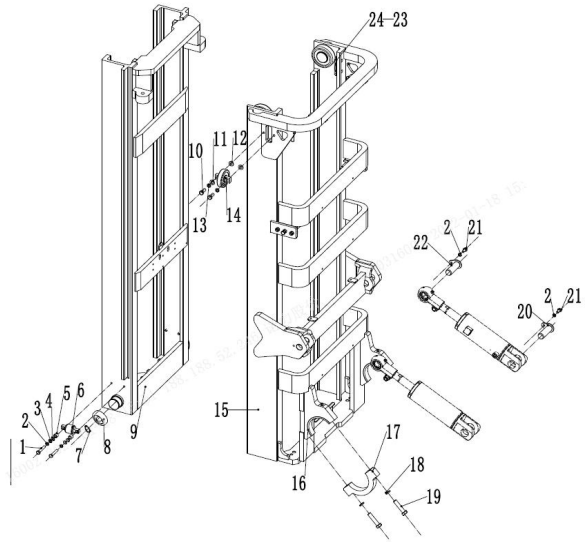

256898501052 短起升油缸(两级全自由门架)/SHORT LIFTING CYLINDER (two stage full free)

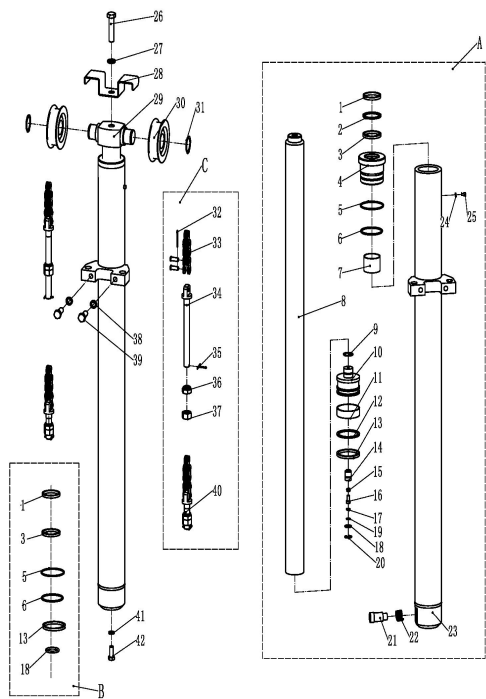

序号/NO	编码/SN	名称	Name	数量/QTY	备注/Remark
A	255043510068	油缸 (M) (H=3000)	Cylinder (M)Φ85xΦ60x772(H=3000)	1	包含/Inc. 1-25
	255043510066	油缸 (M) (H=2000)	Cylinder (M)Φ85xΦ60x522(H=2000)	1	
	255043510067	油缸 (M) (H=2500)	Cylinder (M)Φ85xΦ60x647(H=2500)	1	
	255043510069	油缸 (M) (H=3300)	Cylinder (M)Φ85xΦ60x847(H=3300)	1	
	255043510070	油缸 (M) (H=3500)	Cylinder (M)Φ85xΦ60x897(H=3500)	1	
	255043510071	油缸 (M) (H=3600)	Cylinder (M)Φ85xΦ60x922(H=3600)	1	
	255043510072	油缸 (M) (H=3700)	Cylinder (M)Φ85xΦ60x947(H=3700)	1	
	255043510073	油缸 (M) (H=4000)	Cylinder (M)Φ85xΦ60x1047(H=4000)	1	
	255043510074	油缸 (M) (H=4300)	Cylinder (M)Φ85xΦ60x1122(H=4300)	1	
	255043510075	油缸 (M) (H=4500)	Cylinder (M)Φ85xΦ60x1172(H=4500)	1	
	255043510076	油缸 (M) (H=5000)	Cylinder (M)Φ85xΦ60x1297(H=5000)	1	
	255043510077	油缸 (M) (H=5500)	Cylinder (M)Φ85xΦ60x1447(H=5500)	1	
	255043510078	油缸 (M) (H=6000)	Cylinder (M)Φ85xΦ60x1572(H=6000)	1	
B	255098510004	密封件修理包(二级全自由中间缸)	Seal kits (two stage full free middle cy	1	包含
C	256843515001	起升链条LH1634-37	Lifting chain LH1634-37	2	H=2000
	256843515002	起升链条LH1634-47	Lifting chain LH1634-47	2	H=2500
	254043510054	起升链条LH1634-53	Lifting chain LH1634-53	2	H=3000
	256144014005	起升链条LH1634-59	Lifting chain LH1634-59	2	H=3300
	263043510059	起升链条LH1634-63	Lifting chain LH1634-63	2	H=3500
	254043510055	起升链条LH1634-57	Lifting chain LH1634-57	2	H=3600 H=3700
	254043510056	起升链条LH1634-65	Lifting chain LH1634-65	2	H=4000
	254044010055	起升链条LH1634-71	Lifting chain LH1634-71	2	H=4300
	254043510060	起升链条LH1634-75	Lifting chain LH1634-75	2	H=4500
	256144014007	起升链条LH1634-85	Lifting chain LH1634-85	2	H=5000
	256843515003	起升链条LH1634-97	Lifting chain LH1634-97	2	H=5500
256144014009	起升链条LH1634-107	Lifting chain LH1634-107	2	H=6000	
1	▲	防尘圈	Dust ring 60x74x8/11	1	
2	▲	挡片60×70×3	Gatch 60×70×3	1	
3	▲	轴用密封圈	Seal ring 60×70×6	1	
4	▲	导向套	Guide sleeve	1	

256898501052 短起升油缸(两级全自由门架)/SHORT LIFTING CYLINDER (two stage full free)

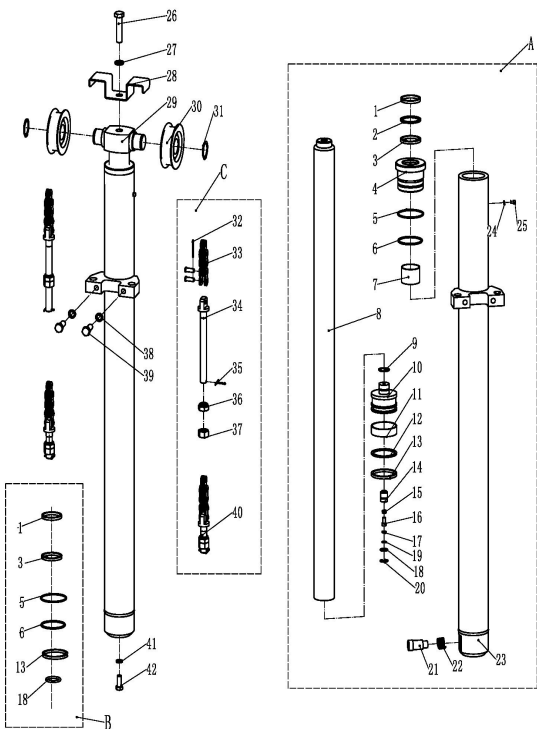

序号/NO	编码/SN	名称	Name	数量/QTY	备注/Remark
5	▲	O型密封圈	O ring 84.4x3.1	1	
6	▲	O型密封圈	O ring 77.5x3.55	1	
7	▲	钢背轴承6035	Bearing 6035	1	
8	▲	活塞杆	Piston rod	1	
9	▲	钢丝挡圈	Circlip	1	
10	▲	活塞总成	Piston assembly	1	
11	▲	支承环D85x20x2.5	Back up ring D85x20x2.5	1	
12	▲	挡圈85x70x3	Circlip 85x70x3	1	
13	▲	密封圈	Seal ring 85x70x9	1	
14	▲	阀套	Valve bushing	1	
15	▲	弹簧	Spring	1	
16	▲	阀芯	Valve plug	1	
17	▲	挡片	Catch	1	
18	▲	O型密封圈	O ring D15.8x2.4	1	
19	▲	挡圈φ12	Circlip φ12	1	
20	▲	挡圈φ22	Circlip φ22	1	
21	▲	滑阀	Slide valve	1	
22	▲	弹簧	Spring	1	
23	▲	缸体	Cylinder	1	
24	▲	垫片	Spacer	1	
25	▲	螺钉M5x5	Screw M5x5	1	
26	910100100071	螺栓GB5782-M16x50-8.8	Bolt GB5782-M16x50-8.8	1	
27	910400500010	弹簧垫圈GB93-16	Washer GB93-16	1	
28	255043520020	挡链板	Chain plate	1	
29	255043520006	缸头	Cylinder head	1	
30	940200500001	链轮轴承780708K-φ110xφ40x27	Chain wheel bearing 780708K-φ110xφ40x27	1	
31	910401300020	轴用弹性挡圈GB894.1-40	Circlip GB894.1-40	1	
32	▲	开口销2.5x40	Split pin 2.5x40	2	
33	▲	LH1623板式链	LH1623 chain	2	
34	▲	长端接头	Joint	2	
35	▲	开口销3.2x30	Split pin 3.2x30	2	

256898501053 起升油缸(两级全自由门架)/LIFTING CYLINDER (two stage full free)

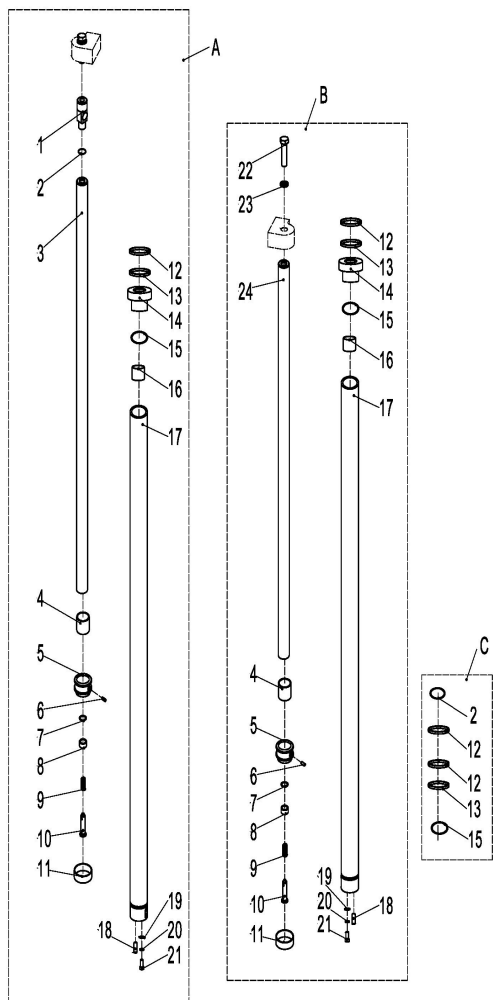

序号/NO	编码/SN	名称	Name	数量/QTY	备注/Remark
A	255043510040	油缸(L) (H=2000)	Cylinder (L)Φ50xΦ40x940(H=2000)	1	包含/Inc. 1-21
	255043510041	油缸(L) (H=2500)	Cylinder (L)Φ50xΦ40x1190(H=2500)	1	
	255043510042	油缸(L) (H=3000)	Cylinder (L)Φ50xΦ40x1440(H=3000)	1	
	255043510043	油缸(L) (H=3300)	Cylinder (L)Φ50xΦ40x1590(H=3300)	1	
	255043510044	油缸(L) (H=3500)	Cylinder (L)Φ50xΦ40x1690(H=3500)	1	
	255043510045	油缸(L) (H=3600)	Cylinder (L)Φ50xΦ40x1740(H=3600)	1	
	255043510046	油缸(L) (H=3700)	Cylinder (L)Φ50xΦ40x1790(H=3700)	1	
	255043510047	油缸(L) (H=4000)	Cylinder (L)Φ50xΦ40x1890(H=4000)	1	
	255043510048	油缸(L) (H=4300)	Cylinder (L)Φ50xΦ40x2040(H=4300)	1	
	255043510049	油缸(L) (H=4500)	Cylinder (L)Φ50xΦ40x2140(H=4500)	1	
	255043510050	油缸(L) (H=5000)	Cylinder (L)Φ50xΦ40x2390(H=5000)	1	
	255043510051	油缸(L) (H=5500)	Cylinder (L)Φ50xΦ40x2590(H=5500)	1	
	255043510052	油缸(L) (H=6000)	Cylinder (L)Φ50xΦ40x2840(H=6000)	1	
	B	255043510053	油缸(R) (H=2000)	Cylinder (R)Φ50xΦ40x940(H=2000)	
255043510054		油缸(R) (H=2500)	Cylinder (R)Φ50xΦ40x1190(H=2500)	1	
255043510055		油缸(R) (H=3000)	Cylinder (R)Φ50xΦ40x1440(H=3000)	1	
255043510056		油缸(R) (H=3300)	Cylinder (R)Φ50xΦ40x1590(H=3300)	1	
255043510057		油缸(R) (H=3500)	Cylinder (R)Φ50xΦ40x1690(H=3500)	1	
255043510058		油缸(R) (H=3600)	Cylinder (R)Φ50xΦ40x1740(H=3600)	1	
255043510059		油缸(R) (H=3700)	Cylinder (R)Φ50xΦ40x1790(H=3700)	1	
255043510060		油缸(R) (H=4000)	Cylinder (R)Φ50xΦ40x1890(H=4000)	1	
255043510061		油缸(R) (H=4300)	Cylinder (R) Φ 50x Φ 40x2040 (H=4300)	1	
255043510062		油缸(R) (H=4500)	Cylinder (R) Φ 50x Φ 40x2140 (H=4500)	1	
255043510063		油缸(R) (H=5000)	Cylinder (R) Φ 50x Φ 40x2390 (H=5000)	1	
255043510064		油缸(R) (H=5500)	Cylinder (R) Φ 50x Φ 40x2590 (H=5500)	1	
255043510065		油缸(R) (H=6000)	Cylinder (R) Φ 50x Φ 40x2840 (H=6000)	1	
C		255098510002	密封件修理包(二级全自由起升缸)	Seal kits (two stage full free lif	2
1	▲	左连接杆	Connecting rod	1	
2	▲	O型密封圈	O ring 26x2.4	1	
3	▲	左柱塞杆总成	Piston rod assembly	1	
4	▲	调整套	Adjusting bushing	2	

256898501055 单附加管路(两级全自由门架)/pipeline installation (two stage full free)

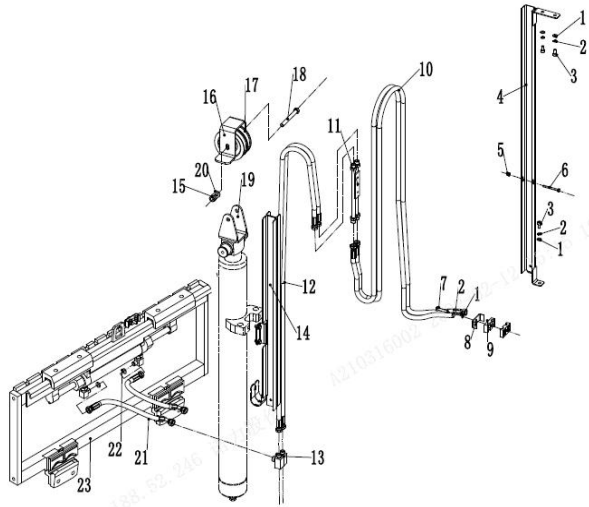

序号/NO	编码/SN	名称	Name	数量/QTY	备注/Remark
1	910400100006	平垫圈GB97.1-8-200HV	Washer GB97.1-8-200HV	11	
2	910400500006	弹簧垫圈GB93-8	Washer GB93-8	11	
3	910200200057	螺钉GB70.1-M8x20-8.8	Screw GB70.1-M8x20-8.8	7	
4	255028510001	外导槽焊合L=670	Groove welding L=670	1	H=2000
4	255028510002	外导槽焊合L=840	Groove welding L=840	1	H=2500
4	255028510003	外导槽焊合L=1090	Groove welding L=1090	1	H=3000
4	255028510004	外导槽焊合L=1240	Groove welding L=1240	1	H=3300/3500
4	255028510005	外导槽焊合L=1390	Groove welding L=1390	1	H=3600/3700
4	255028510006	外导槽焊合L=1640	Groove welding L=1640	1	H=4000
5	910300500003	螺母GB889.1-M6-10	Nut GB889.1-M6-10	2	
6	910200200046	螺钉GB70.1-M6x60-8.8	Screw GB70.1-M6x60-8.8	2	
7	910100300025	螺栓GB5783-M8x35-8.8	Bolt GB5783-M8x35-8.8	4	
8	255028520035	安装板(管夹)	Pipe press fixedly plank	1	
9	255028520034	胶管固定块	Hose fixing bloke	2	
10	252030520016	液压管总成(直)10-L2220-1SC-60°	Hydraulic hose assembly 10-L2220-1SC-60°	2	H=2000
10	254130520009	液压管总成(直)10-L2470-1SC-60°	Hydraulic hose assembly 10-L2470-1SC-60°	2	H=2500
10	263028520010	液压管总成(直)10-L2940-1SC-60°	Hydraulic hose assembly 10-L2940-1SC-60°	2	H=3000
10	255031020013	液压管总成(直)10-L3180-1SC-60°	Hydraulic hose assembly 10-L3180-1SC-60°	2	H=3300/3500
10	254128520039	液压管总成(直)10-L3250-1SC-60°	Hydraulic hose assembly 10-L3250-1SC-60°	2	H=3600/3700
10	255028520059	液压管总成(直)10-L3600-1SC-60°	Hydraulic hose assembly 10-L3600-1SC-60°	2	H=4000
11	255028510022	过渡钢管	Transition steel pipe	1	
12	255028520008	液压管总成(直)10-L1030-1SC-60°	Hydraulic hose assembly10-L1030-1SC-60°	2	H=2000
12	255028520009	液压管总成(直)10-L1280-1SC-60°	Hydraulic hose assembly10-L1280-1SC-60°	2	H=2500
12	255028520010	液压管总成(直)10-L1470-1SC-60°	Hydraulic hose assembly10-L1470-1SC-60°	2	H=3000
12	255028520011	液压管总成(直)10-L1620-1SC-60°	Hydraulic hose assembly10-L1620-1SC-60°	2	H=3300
12	255028520012	液压管总成(直)10-L1730-1SC-60°	Hydraulic hose assembly10-L1730-1SC-60°	2	H=3500
12	255028520013	液压管总成(直)10-L1550-1SC-60°	Hydraulic hose assembly10-L1550-1SC-60°	2	H=3600/3700
12	255028520015	液压管总成(直)10-L1770-1SC-60°	Hydraulic hose assembly10-L1770-1SC-60°	2	H=4000
13	255029020024	接头(锁定弯)8-2xM16x1.5-60°	Joint 8-2XM16x1.5-60°	2	
14	255028510011	内导槽焊合L=545	Groove welding L=545	1	H=2000
14	255028510012	内导槽焊合L=670	Groove welding L=670	1	H=2500

256898501056 双附加管路(两级全自由门架)/pipeline installation (two stage full free)

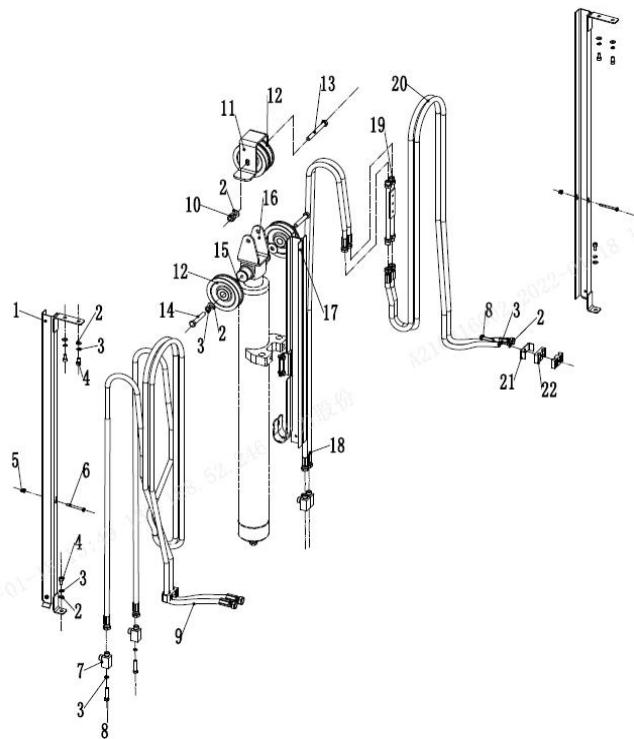

序号/NO	编码/SN	名称	Name	数量/QTY	备注/Remark
1	255029010001	外导槽焊合L=670	Groove welding L=670	1	H=2000
1	255029010002	外导槽焊合L=840	Groove welding L=840	1	H=2500
1	255029010003	外导槽焊合L=1090	Groove welding L=1090	1	H=3000
1	255029010004	外导槽焊合L=1240	Groove welding L=1240	1	H=3300/3500
1	255029010005	外导槽焊合L=1390	Groove welding L=1390	1	H=3600/3700
1	255029010006	外导槽焊合L=1640	Groove welding L=1640	1	H=4000
2	910400100006	平垫圈GB97.1-8-200HV	Washer GB97.1-8-200HV	10	
3	910400500006	弹簧垫圈GB93-8	Washer GB93-8	13	
4	910200200057	螺钉GB70.1-M8x20-8.8	Screw GB70.1-M8x20-8.8	13	
5	910300500003	螺母GB889.1-M6-10	Nut GB889.1-M6-10	3	
6	910200200046	螺钉GB70.1-M6x60-8.8	Screw GB70.1-M6x60-8.8	3	
7	255029020024	接头(锁定弯)8-2xM16x1.5-60°	Joint 8-2xM16x1.5-60°	4	
8	910100300025	螺栓GB5783-M8x35-8.8	Bolt GB5783-M8x35-8.8	4	
9	284023520003	液压管总成(90°)10-L2500-1SC-60°	Hydraulic hose assembly (90°) 10-L	2	H=2000
9	255028520042	液压管总成(90°)10-L2500-1SC-60°	Hydraulic hose assembly (90°) 10-L	2	H=2500
9	252028520022	液压管总成(90°)10-L2500-1SC-60°	Hydraulic hose assembly (90°) 10-L	2	H=3000
9	252030520003	液压管总成(90°)10-L2500-1SC-60°	Hydraulic hose assembly (90°) 10-L	2	H=3300/3500
9	252030520001	液压管总成(90°)10-L3600-1SC-60°	Hydraulic hose assembly (90°) 10-L	2	H=3600/3700
9	252030520014	液压管总成(90°)10-L3900-1SC-60°	Hydraulic hose assembly (90°) 10-L	2	H=4000
10	910300500006	螺母GB889.1-M12-10	Nut GB889.1-M12-10	1	
11	255028520043	挡板	board	1	
12	255030520021	滑轮Φ110x27(单槽)	Pulley Φ110x27	4	
13	910100100058	螺栓GB5782-M12x100-8.8	Bolt GB5782-M12x100-8.8	1	
14	910100300054	螺栓GB5783-M12x50-8.8	Bolt GB5783-M12x50-8.8	2	
15	910400200005	大垫圈GB96.1-12-200HV	Washer GB96.1-12-200HV	2	
16	255030520026	滑轮架体	Pulley frame	1	
17	255029010008	内导槽焊合L=545	Groove welding L=545	1	H=2000
17	255029010009	内导槽焊合L=670	Groove welding L=670	1	H=2500
17	255029010010	内导槽焊合L=795	Groove welding L=795	1	H=3000
17	255029010011	内导槽焊合L=870	Groove welding L=870	1	H=3300
17	255029010014	内导槽焊合L=920	Groove welding L=920	1	H=3500

256898501057 电器系统/ELECTRONIC

序号/NO	编码/SN	Name	名称	数量/QTY	备注/Remark
1	920500100002	Buzzer (DJB-24B)	喇叭蜂鸣器DJB-24B	1	
2	251233020001	Integrated electrical box	集成电器盒	1	
3	256733010101	Controller Assembly (ACM-4P25Q)	电控组件(ACM系统-4P25Q)	1	ACM系统 (25Q)
	256733010102	Controller Assembly (Curtis-4P25Q)	电控组件(Curtis系统-4P25Q)	1	Curtis系统 (25Q)
	256833010101	Controller Assembly (ACM-4P30Q)	电控组件(ACM系统-4P30Q)	1	ACM系统 (30Q)
	256833010102	Controller Assembly (Curtis-4P30Q)	电控组件(Curtis系统-4P30Q)	1	Curtis系统 (30Q)
	256933010021	Controller Assembly (Inmotion-4P30Q)	电控组件(Inmotion-4P30Q)	1	Inmotion系统
	256833010105	Controller Assembly (ACM系统-4P30Q)	电控组件(ACM系统-4P30Q-FS)	1	ACM系统
	256833010012	Controller Assembly (Curtis-F系列)	电控组件(Curtis-F系列)	1	Curtis-F系列
4	256833010013	Wire Harness (Curtis-F)	车身线束(Curtis-F系列)	1	Curtis-F系列
	256933010001	Wire Harness (ACM-4P30Q)	车身线束(ACM系统-4P30Q-新车架)	1	ACM系统
	256833010001	Wire Harness (ACM-4P30Q)	车身线束(ACM系统-4P30Q-旧车架)	1	ACM系统
	256833010010	Wire Harness (Curtis-4P30Q)	车身线束(Curtis系统-4P30Q)	1	Curtis系统
	256933010020	Wire Harness (Inmotion-4P30Q)	车身线束(Inmotion-4P30Q)	1	Inmotion系统
5	921700100026	Accelerator (JCTA-1801E)	加速器JCTA-1801E	1	ACM系统
	921700100015	Accelerator (JCTH2-5L)	加速器JCTH2-5L	1	Inmotion系统
	921700100005	Accelerator (FZ3-132-133)	加速器FZ3-132-133	1	Curtis系统
6	920201000002	Pedal Switch (JK231)	脚踏开关JK231	1	
7	920500100001	Horn (125-DC24V)	喇叭 125-DC24V	1	
8	921900100004	USB	转换器DC24V转5V	1	Opiton
9	920200800020	Warp Switch (YB-nuoli-003)	翘板开关YB-nuoli-003	1	
10	920200800013	Combination Switch	组合开关	1	
11	920200200030	KEY	钥匙开关(一档双路)	1	
12	921100100108	Display (D28C-CC-K)	仪表D28C-CC-K	1	ACM系统 (25/3Q)
	921100100063	Display (3401T-12-96V)	仪表3401T-12-96V	1	Curtis系统
	921100100039	Display (IDD-E-35CD17B)	仪表IDD-E-35CD17B	1	Inmotion系统
13	920200100020	Emergency Stop Switch (LAY39-01MJ-RC)	急停开关LAY39-01MJ-RC	1	
14	921900100017	DC-DC80V/24V	转换器WDC300N1	1	
15	920200300004	Micro Switch (RZ-15GQ22-B3)	微动开关RZ-15GQ22-B3	4	
16	922000100053	Grouped Lamps FLDJ-SSWD-003	灯FLDJ-SSWD-003	2	
17	922000100048	Head Lamp FLDD-4Z-002	灯FLDD-4Z-002	3	

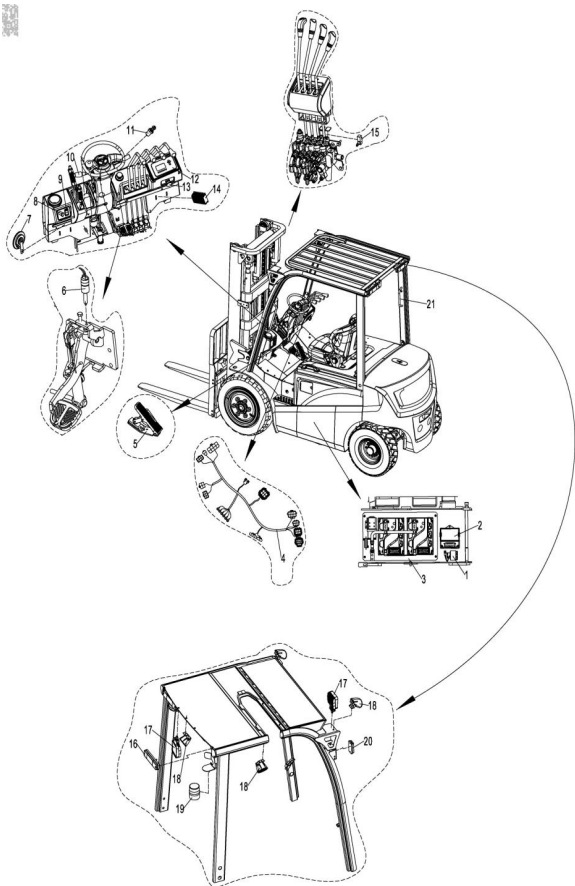

256898501060 电控组件/ELECTRONIC COMPONENTS—Curtis-F系统

序号/NO	编码/SN	Name	名称	数量/QTY	备注/Remark
1	920700100006	Contacto(DC80V-SW200-583)	接触器DC80V-SW200-583	1	
2	921400100177	ControllerAC-F6-A-80-450-101	控制器AC-F6-A-80-450-101	1	泵(Curtis-F)
3	921400100177	ControllerAC-F6-A-80-450-101	控制器AC-F6-A-80-450-101	1	牵引(Curtis-F)
4	920100100014	Fuse 500A(ceramic)	保险丝500A(陶瓷)	1	

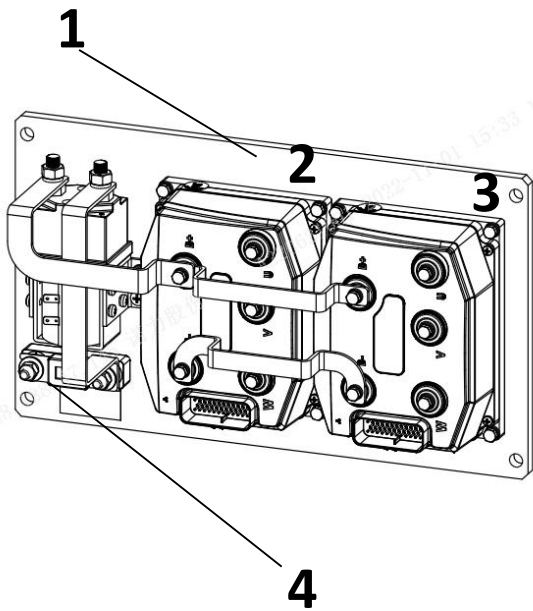

256898501061 电控组件/ELECTRONIC COMPONENTS—Curtis系统

序号/NO	编码/SN	Name	名称	数量/QTY	备注/Remark
1	920700100006	Contactator (DC80V-SW200-583)	接触器DC80V-SW200-583	1	
2	921400100158	Controller1232SE-6321	控制器1232SE-6321	1	25Q牵引 (Curtis)
	921400100054	Controller1234SE-6321	控制器1234SE-6321	1	30/35Q牵引
3	921400100158	Controller1232SE-6321	控制器1232SE-6321	1	25Q泵 (Curtis)
	921400100054	Controller1234SE-6321	控制器1234SE-6321	1	30/35Q泵 (Curtis)
4	920100100014	Fuse 500A(ceramic)	保险丝500A(陶瓷)	1	

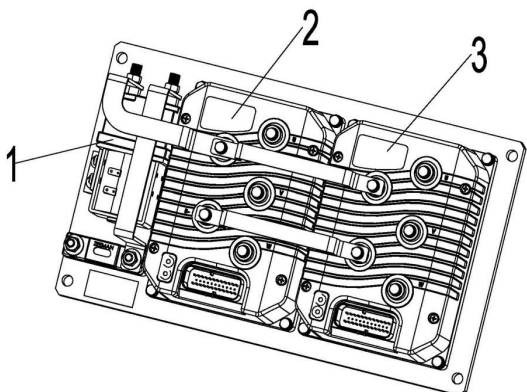

4

256898501062 蓄电池/BATTERY

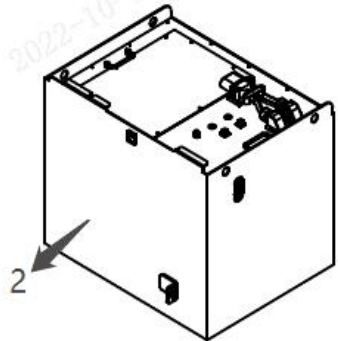
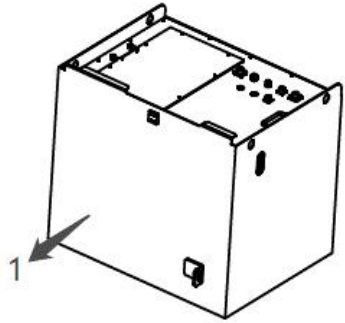

序号/NO	编码/SN	Name	名称	数量/QTY	备注/Remark
1	256737010002	Lithium battery LFP80B-200R-GF	锂电池LFP80B-200R-GF	1	200Ah【3年】
1	256737010003	Lithium battery LFP80B-200R-GF1	锂电池LFP80B-200R-GF1	1	200Ah【5年】
1	256737010004	Lithium battery LFP80A-300R-GF	锂电池LFP80A-300R-GF	1	300Ah【3年】
1	256737010005	Lithium battery LFP80A-300R-GF1	锂电池LFP80A-300R-GF1	1	300Ah【5年】
1	256737010007	Lithium battery LFP80B-400R-GF1	锂电池LFP80B-400R-GF1	1	400Ah【5年】
1	256737010015	Lithium battery LFP80A-554R-GF1	锂电池LFP80A-554R-GF1	1	554Ah【5年】
1	256737010008	Lithium battery LFP80B-200R-H-GF1	锂电池LFP80B-200R-H-GF1	1	200Ah【带加热】
1	256737010009	Lithium battery LFP80A-300R-H-GF1	锂电池LFP80A-300R-H-GF1	1	300Ah【带加热】
1	256737010010	Lithium battery LFP80B-400R-H-GF1	锂电池LFP80B-400R-H-GF1	1	400Ah【带加热】
2	256737013101	Lithium battery LFP80B-200R-GF2	锂电池LFP80B-200R-GF2	1	200Ah【国际版】
2	256737013102	Lithium battery LFP80A-300R-GF2	锂电池LFP80A-300R-GF2	1	300Ah【国际版】
2	256737013103	Lithium battery LFP80B-400R-GF2	锂电池LFP80B-400R-GF2	1	400Ah【国际版】
2	256737013104	Lithium battery LFP80A-554R-GF2	锂电池LFP80A-554R-GF2	1	554Ah【国际版】
2	256737013105	Lithium battery LFP80B-200R-H-GF2	锂电池LFP80B-200R-H-GF2	1	200Ah【加热国际】
2	256737013106	Lithium battery LFP80A-300R-H-GF2	锂电池LFP80A-300R-H-GF2	1	300Ah【加热国际】
2	256737013107	Lithium battery LFP80B-400R-H-GF2	锂电池LFP80B-400R-H-GF2	1	400Ah【加热国际】
2	256737013108	Lithium battery LFP80A-554R-H-GF2	锂电池LFP80A-554R-H-GF2	1	554Ah【加热国际】
2	256737013109	Lithium battery LFP80B-200AS-GF2	锂电池LFP80B-200AS-GF2	1	200Ah【安德森】
2	256737013110	Lithium battery LFP80A-300AS-GF2	锂电池LFP80A-300AS-GF2	1	300Ah【安德森】
2	256737013111	Lithium battery LFP80B-400AS-GF2	锂电池LFP80B-400AS-GF2	1	400Ah【安德森】
2	256737013112	Lithium battery LFP80A-554AS-GF2	锂电池LFP80A-554AS-GF2	1	554Ah【安德森】
2	256737013113	Lithium battery LFP80B-200AS-H-GF2	锂电池LFP80B-200AS-H-GF2	1	200Ah【加热安德】
2	256737013114	Lithium battery LFP80A-300AS-H-GF2	锂电池LFP80A-300AS-H-GF2	1	300Ah【加热安德】
2	256737013115	Lithium battery LFP80B-400AS-H-GF2	锂电池LFP80B-400AS-H-GF2	1	400Ah【加热安德】
2	256737013116	Lithium battery LFP80A-554AS-H-GF2	锂电池LFP80A-554AS-H-GF2	1	554Ah【加热安德】
3	256836513001	Li Charger HW80V65A(three phase 3	锂电充电器HW80V65A(三相380V)	1	配200Ah
3	256836513002	Li Charger HW80V100A(three phase	锂电充电器HW80V100A(国内三相380V)	1	配200/300Ah
3	256836513003	Li Charger HW80V150A(three phase	锂电充电器HW80V150A(国内三相380V)	1	配300/400Ah
3	256836513004	Li Charger HW80V200A(three phase	锂电充电器HW80V200A(国内三相380V)	1	配400/554Ah
3	256736512004	Li Charger ADY80V35A(110V+Americar	锂电充电器ADY80V35A(110V+美式)	1	
3	256736512005	Li Charger ADY80V35A(220V+CN)	锂电充电器ADY80V35A(220V+国标)	1	

